

INSTALLATION, OPERATION AND MAINTENANCE MANUAL

PRISMATIC AND FLAT GLASS WATER GAGE MAINTENANCE INSTRUCTIONS

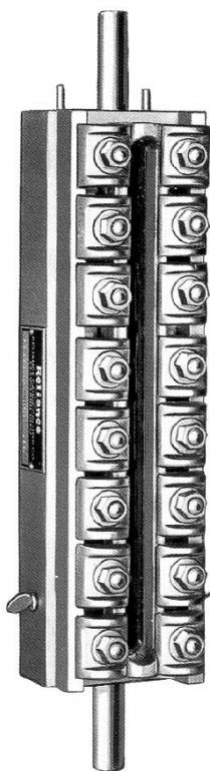

Flat Glass Gage Glass

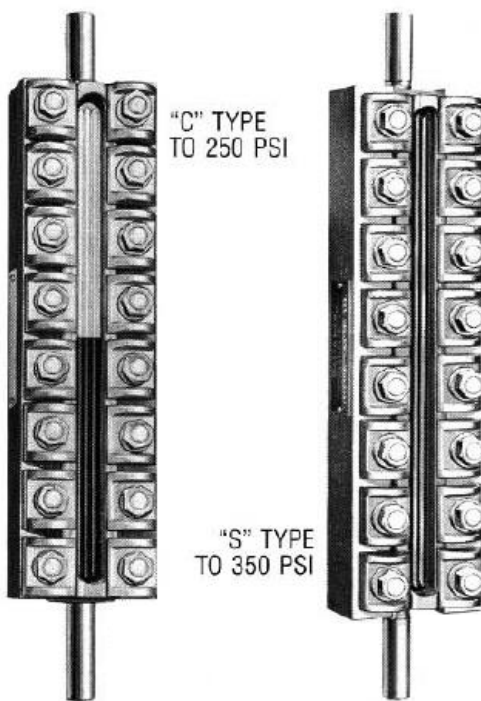

Prismatic Gage Glass



16633 FOLTZ PARKWAY, STRONGSVILLE, OH 44149
TEL 800-992-2843 WWW.ERNSTFLOW.COM INFO@ERNSTFLOW.COM

Unpacking and inspection

Upon receipt of the Boiler Drum Level instruments, examine the contents of the container(s) for damage. Report any faulty conditions as soon as possible to your carrier to avoid acceptance of damaged goods. Ernst Flow Industries will not be responsible for goods damaged in shipping or storage, or subsequent loss or damage due to improper storage or exposure as a result of damage to shipping containers. Submit a digital photo of any damaged equipment and container to Ernst Flow Industries, if possible

Verify that all materials are present as recorded on the Packing List provided with each shipment. Report any discrepancies to Ernst Flow Industries immediately. Have the Ernst Flow Industries order number and shipping waybill available at the time of your call.

Handling

Your Ernst Flow Industries shipment has been carefully packed. However, the shipment may include spare parts, temporary water gages for “Boil-out” purposes, maintenance instructions, and engineering drawings.

Upon receipt of the order, the equipment and above items should be identified and verified against the packing list. Any documentation that has been provided should be directed to the appropriate personnel.

Care should be exercised as the items are uncrated. The shipment may contain fragile glass components. If any equipment appears to have been damaged from shipment, please contact your local Ernst Flow Industries representative or the factory immediately.

Storage

Ernst Flow Industries Boiler Trim products should be stored in a dry and sheltered area prior to installation. The equipment provided may consist of electrical items that are intended for either indoor or outdoor use. As a matter of good practice, dry storage will eliminate the potential for water damage. The temperature of the storage area should not exceed 150 degrees F. (65.5 degrees C) or drop below 32 degrees F (0 degrees C).

Boil-out Gage Practice and Policy

On new boiler installations, it is common procedure to initially operate the boiler at a reduced pressure for a short time to 'cook out' foreign materials (pipe joint compound, grease, oil, flux, etc.) that remain in the drum or other pressurized parts of the system after the boiler has been constructed. During this boil-out period, most of the suspended or dissolved debris is flushed out with blow-down discharges. However, a small amount of residue is unavoidably deposited as a film on all internal wetted surfaces... including those of the water gage glass. This type of scum layer is nearly impossible to remove by blowing down the gage glass, particularly if the gage glasses are protected by mica shields, as they must be, in high pressure installations.

As a practical matter, it is more expedient to employ an inexpensive temporary level gage, which can be discarded or returned after the boil-out procedure, rather than to use then rebuild the gage glass intended for regular service. For boil-out purposes on new water columns, Ernst Flow Industries provides a temporary level gage at no charge, or at a refundable charge, under one of the following conditions:

- 1) When a Prismatic, Flat Glass, or Simpliport gage having $\frac{3}{4}$ " O.D. end nipples is supplied as part of a water column, and the boil-out pressure will not exceed 200 PSIG, Ernst Flow Industries automatically will furnish for temporary boil-out service the following parts at no charge:

1 pc. – $\frac{3}{4}$ " O.D. tubular glass gage cut to the proper length 2 pcs. –

Rubber packing rings (*)

1 pc. – Low visibility shield (so that low vision in the tubular glass gage is the same as in the gage glass that will be used for regular service).

At the conclusion of the boil-out procedure, all of the above parts should be discarded. When the gage having stainless steel nipples is installed, it is essential that the appropriate (non- rubber) packing rings are used, to assure durable sealing of the stainless steel nipples.

- 2) When a gage glass having flanged connections is supplied as part of a water column, and the boil-out pressure will not exceed 200 PSIG, Ernst Flow Industries will furnish the following parts at no charge:

1 set – VB991 gage valves with $\frac{1}{2}$ " MNPT connections

1 pc. $\frac{5}{8}$ " O.D. tubular glass gage cut to the proper length 1 pc. – Low visibility shield.

The boil-out gage valves should be temporarily installed in the $\frac{1}{2}$ " FNPT "Test" connections in the flanges of the regular water gage shut-off valves, which are on the water column. This equipment may be discarded after the boil-out has been completed.

- 3) On installations like the above, but where the boil-out pressure will exceed 200 PSIG, consult Ernst Flow Industries to discuss options for an appropriate temporary use gage and valves. The cost of this assembly will be listed separately on our order invoice. However, full credit will be issued upon its return to Ernst Flow Industries.

* Bronze valves are supplied with rubber packing rings. These are to be used for the boil-out procedure. Steel valves are supplied with packing cartridges and separate rubber packing rings (to be used for boil-out).

Recommended Blow-Down Procedure for Water Columns and Gage Glasses

The importance of proper cleaning and maintenance of the water column and the water gage glass, or sight glass, cannot be stressed enough. The water column must be kept clean to ensure the water level in the gage glass accurately represents the water level in the boiler. Note that the frequency and method of blow-down may affect service life and performance of the water column and gage glass.

The water gage glass on a boiler enables the operator to visually observe and verify the actual water level in the boiler. However, if not properly cleaned and maintained, a gage glass can seem to show that there is sufficient water, when the boiler is actually operating in a low or low water condition. A stain or coating can develop on the inside of the glass where it is in contact with boiling water. After a time, this stain gives the appearance of water in the boiler, especially when the glass is completely full or empty of water.

Also, the connection lines to the gage glass can become clogged with sediment and show normal water levels when water may be low. After performing the blow-down procedure, if the water level does not return to normal promptly, the connecting piping may be partially clogged and have to be cleaned.

Ernst Flow Industries suggests the following blow-down procedure:

1. Close both the steam and water valves between the boiler drum and the water column or water gage.
2. Open the drain valve fully on the bottom of the water column or water gage.
3. Crack open the steam valve and allow a gentle rush of steam to pass through the water column or water gage. The steam should not pass through for longer than 20 seconds.
4. Close the steam valve.
5. Inspect the water gage to insure that all foreign matter is flushed from the glass or mica. If the gage is not visually clean, repeat steps 3 and 4.
6. Close the blow-down valve and simultaneously open the steam and water valves, slowly bringing the equipment back to a normal operating level.
7. Water should enter the gage glass quickly when the blow-down valve is closed. This will indicate that the lines are free of sludge, sediment, or scale buildup.

Note:

1. Any trip or alarm circuits that are actuated by the equipment being blown-down should be bypassed to prevent false alarms during the blow-down process.
2. Blow-down should be conducted on a weekly basis, or as necessary, based on water quality.
3. Always notify control room personnel prior to conducting a Blow-Down to prevent any false alarms or false trips.

Recommended Maintenance and Annual Inspections

Regarding any recommended maintenance procedures or annual inspections, we suggest any device containing probes should be inspected on an annual basis for contaminated probes and wire secure terminations.

Caution: Before proceeding, follow any and all plant lock out - tag out procedures required. Verify that all power is turned off to the probes. If under pressure, the equipment should be isolated, or the boiler should be shut down *before* proceeding with the installation. Open drain valve to eliminate any trapped pressure. All inspection and installation steps should be performed by a qualified technician and should be executed in accordance with all applicable national and local codes.

With no pressure or elevated temperature, beyond ambient conditions, at least one probe should be removed for inspection. Ideally, for devices containing multiple probes, we suggest removing one probe from an upper indication location (normally in steam area) and one probe from a lower indication location (normally in water area) for inspection. If any probes display signs of contamination, they can be cleaned with a mild detergent and re-installed using a new sealing gasket, if applicable. Refer to the attached IOM # E189-A for additional details. If a probe exhibits and contamination across the length of the insulator, which cannot be easily cleaned, the probe should be replaced.

5. Once a gauge glass has been removed from its mounting, *regardless* of the reason for its removal, discard the glass and washers and replace them with new ones. **Used gauge glass and washers may contain hidden damage.**
6. Inspect the gauge valves for the following:
 - evidence of leakage around valve stems
 - evidence of leakage around vessel connections
 - evidence of leakage around the gauge glass nuts
 - evidence of leakage at drain cock or drain plug
 - signs of corrosion of any internal or external areas

If any component parts of the liquid level gauge valves show signs of wear or damage, they must be replaced. Contact Ernst Flow for the correct replacement parts for your model level gauge.

Note: Detailed sectional drawings are available for most Ernst Flow Industries liquid level gauge valve sets. These drawings can help to identify necessary spare and replacement parts. Contact Ernst Flow Industries for availability.

Neoprene® is a DuPont registered trademark.

Prismatic and Flat Glass Gages

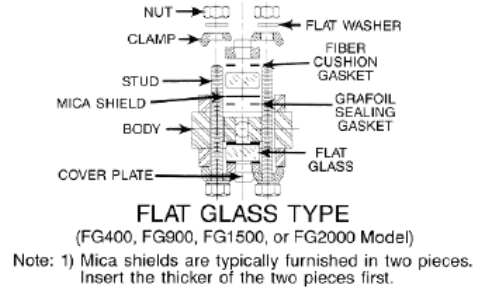
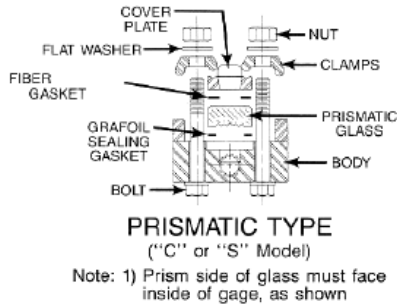

BEFORE YOU INSTALL THE GAGE GLASS:

- Support brackets should be considered for gages over four feet long and weighing in excess of 100 pounds. The support brackets will help prevent overloading of the connecting valves and piping. The brackets will also help prevent damage caused by excessive vibration.
- While the advantage of using automatic ball check valves ahead of a level gage is evident, the principal disadvantage is the check valves will prevent effective blow-down of the gage itself. When the level gage drain valve is opened, pressure inside the level gage drops, and the check valve balls are driven into the almost closed positions by system pressure.
- Confirm that the gage glass model number and the pressure rating, which can be found on the nameplate, meet the required specifications and design conditions for the application.

Maintenance

Water Gage Removal Procedure

This procedure applies to all Ernst Flow Industries water level gages with nipple end connections. Nipple end connected water gages are designed in various models to service pressure up to 1500 PSIG (103.4 BarG) saturated steam applications.

Water gages designed for use with bronze water gage valves have an overall length of 2 3/4" (70mm) less than the design of the water gage valve centers. Water gages designed for use with steel water gage valves have an overall length of 3 1/4" (82.5mm) less than the design of the water gage valve centers.

- 1) Isolate the water gage valves and open the drain valve.
- 2) Remove the packing yoke bolts on steel valves. On bronze valves loosen the nipple packing nut.
- 3) Grasp the water gage firmly and push up into the upper (steam) valve. This action will disengage the water gage from the lower (water) valve.
- 4) Carefully swing the water gage off to one side and drop it out from the steam valve.

Disassembly:

- After pressure is relieved from the gage glass, remove from the boiler drum and lay flat on a workbench
- Loosen end bolting first, working from the opposite ends toward the center of the gage.
- Remove all components including washers, finger clamps, cover plates, gaskets, glass, and Mica shields. Retain the bolting and cover plates. Discard all gaskets, glass, and Mica. Note: **Never** re-use these components, even when they appear to be in perfect condition!

Reassembly:

- Inspect all glass kit components. Verify that the repair kit is the correct one for the model gage that is being repaired. Carefully inspect the glass for any chips, cracks or scratches. Do not use the glass if it is damaged! Inspect the Mica shields and gaskets for any visible signs of damage, Do not use these components if damaged!
- Use a bronze or brass scraper to remove any bits of gasket material that may remain, without causing damage to the gage body or cover plate(s).
- Examine body gasket surfaces for steam cuts or scratches. Gouged or scratched gasket surfaces may be re-machined if necessary. See Ernst Flow Industries Form E190-A for machining details and tolerances.
- Locate the gaskets, Mica (if on Flat Glass Gages), and glass centrally in the seat and cover to avoid any glass-metal contact at the ends or sides.
- Clean and lubricate all fasteners with Molycote or similar high temperature anti-seize lubricant.
- Tighten nuts 'finger tight' in the sequence shown in the sketch. Using a calibrated torque wrench, tighten all nuts in the proper sequence in 1/3rd increments.

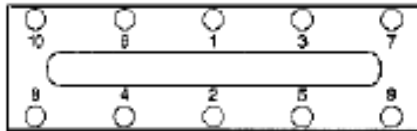

-Torque values

'C' and 'S' Prismatic	40 Ft. Lbs. (54 Newton Meters)
FG400 or FG900 Series	45 Ft. Lbs. (61 Newton Meters)
FG1500 or FG2000 Series	70 Ft. Lbs. (95 Newton Meters)

- Hot torque gage per instructions found on page 9 of this manual.
- Return gage to service
- Note:** Conduct regular inspection of the gage glass. The gage must be repaired if there are any signs of scratches, etching, erosion of the glass, clouding, or deterioration of the glass or Mica shields.

Recommendations and Instructions for Hot Torquing Gage Glasses and Probe Type Devices

When a new piece of equipment, whether a Gage Glass or a Probe* type device is installed, the hot torque procedure must be performed. This ensures that all bolting and components are properly seated for optimum performance. This procedure must also be performed after any maintenance is done to the equipment. Note that only the affected components, such as the installation of a new probe or glass kit, need to be hot torqued.

All work must be done by a qualified technician. All plant rules and procedures must be followed, including any lock out / tag out requirements. Verify that all alarms and trips have been by-passed on probe columns before any maintenance is performed, to prevent any false alarms or wiring hazards.

The hot torque procedure should be performed as follows:

- 1) Isolate the gage glass or probe device from any pressure.
- 2) Fully open the drain valve to evacuate any built up pressures and to allow the contained steam and water to escape during equipment warm up.
- 3) Slowly open the *steam valve* to allow a gentle rush of steam to flow through the equipment. This should take approximately 5 – 10 minutes. The observer should see the High Temperature lubricant “sizzling” and smoke emanating from the gage of column. This is an indication that the equipment has reached the operating temperature.
- 1) When the equipment has been properly heated, close the steam valve. The drain valve should remain open to allow any residual steam or pressure to escape.
- 2) Immediately re-torque the equipment to the correct values stated in the applicable instruction manual. There should be movement of approximately 1/8th of a turn or more.
- 3) If there is no movement of the bolting or probes, the equipment was not heated properly. Repeat the procedure.
- 4) Once the hot torque procedure is completed, close the drain valve, and the equipment can be put back into service. Carefully check for any leaks in the equipment and verify proper operation of all illumination, relay controls and wiring, or other accessories.

Installation Instructions for Model GL-53 Water Gage Illuminators for Tubular Glass Gages or Prismatic Gages

1. General Information

Model GL-53 Water Gage Illuminators are designed to improve the vision of the water level, for plant personnel. If a tubular glass or prismatic type water gage is installed in an area with adequate lighting, a gage illuminator may not be required. However, if the water gage is to be viewed from a distance greater than 25 feet, or in poorly lit areas, then a gage illuminator is recommended.

2. Installation

Model GL-53 illuminators are designed with a ½" female NPT electrical conduit connection. These illuminators should be installed vertically with the conduit connection located at the bottom. A flexible power cord can be temporarily installed on the unit, and used to test the unit. This will enable the installer to optimize the illuminator location, with respect to the gage. **CAUTION: when testing the position of the unit, the housing will become very hot when powered.** Then, a permanent power connection can be installed. Normally, the illuminator will be installed parallel to the gage and off to the left or right side, to prevent obstructing the operator's view of the water gage.

If the illuminator is to be installed with a prismatic type water gage, one illuminator can be used for up to two sections of size 9 glass or approximately 27 inches of water gage viewing.

This illuminator can be installed outdoors.

3. Maintenance

There is no maintenance required, other than the occasional need to service the lamp. For additional instructions, see form E178-A. As an option to extend lamp life, we suggest an illuminator timer: model TPS-120 (for 120 VAC supply) or TPS-240 (for 240 supply). An illuminator timer provides up to 3 minutes of operation time, by depressing a pushbutton. This results in extended lamp life, reduced power consumption and maintenance. Consult Ernst Flow Industries for additional details.

Wiring instructions for the Ernst Flow Industries GL53 Illuminators (for 'C' and 'S' Series Gages).

Note: Make sure that the power is turned off to the supply wiring before connecting the illuminator.

Tools needed:

- Slotted Screwdriver
- 1/2" Wrench

1. Open the illuminator housing by loosening the three hex head cap screws on the end of the unit that secures the Conduit/Lamp assembly in place.

2. Carefully remove the assembly and remove the 60W Frosted Lamp (B) from the illuminator housing and set aside.

3. Loosen the screw (C) from the side of the lamp socket/conduit connector that holds the assembly in place on the pipe nipple.

4. Take the lamp socket/conduit connector assembly (D) off of the housing end piece and set the housing aside.

5. Disassemble the lamp socket/conduit connection assembly by removing the two screws (E) from *inside* of the lamp socket. (Note that there are two small washers on the assembly screws. Do not lose these washers as they are needed for re-assembling the illuminator.)

7. Connect the *black* wire to the 'gold' screw terminal on the bottom of the lamp socket.

8. Connect the *white* wire to the 'silver' screw terminal on the bottom of the lamp socket.

9. Re-assemble the lamp socket/conduit connector assembly using the same two screws with washers inside of the lamp socket. Make sure that the mounting plate is centered on the lamp socket/conduit connector assembly.

10. Thread the lamp socket/conduit connector assembly back into the bottom of the pipe nipple and tighten the holding screw.

11. Carefully screw the lamp into the socket and re-assemble the bottom assembly back onto the illuminator housing (make sure that the gasket between the bottom assembly and housing is in place). Secure by tightening the three hex head cap screws on the bottom side of the housing.

12. Wire the illuminator to the 120 V.* power supply. (*Unless lamp is for 230 V. service) Note that a proper ground wire is recommended.

GL53 Illuminator - 120V.

Specification: 60W/120V

Current Draw: .5 Amps

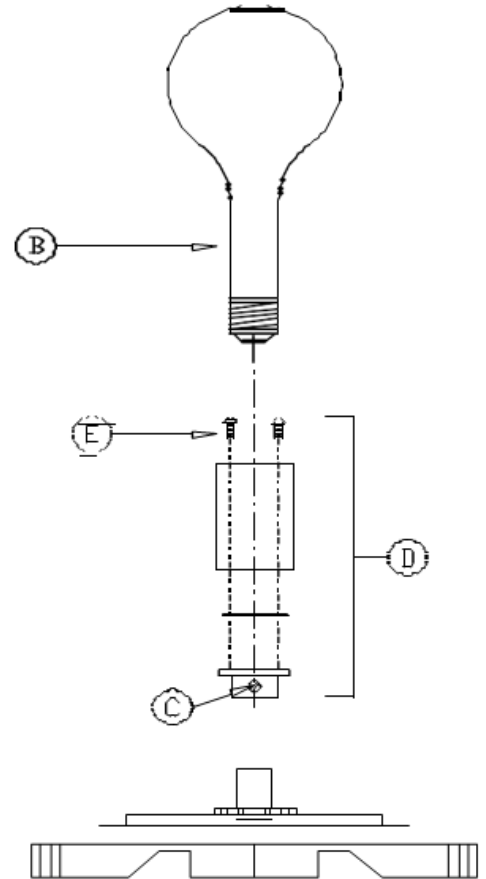

Wiring instructions for the Standard and Vertical Ernst Flow industries Flat Glass Gage Illuminators

Note: Make sure that the power is turned off to the supply wiring before connecting the illuminator.

Tools needed:

– Slotted Screwdriver

1. Open the illuminator housing by loosening the thumb screw (A) in the side of the unit that secures the door assembly in place.
2. Carefully open the door and remove the 150W clear lamp (B) from the inside of the illuminator housing and set aside.
3. Remove the two brass screws (C) from the bottom of the illuminator which hold the lamp socket/conduit connector assembly in place.
4. Take the lamp socket/conduit connector assembly (D) from the illuminator housing and set the housing aside.
5. Disassemble the lamp socket/conduit connection assembly by removing the two screws (E) from *inside* of the lamp socket. (Note that there are two small washers on the assembly screws. Do not lose these washers as they are needed for re-assembling the illuminator.)
6. Slide the conduit connector and mounting plate over the power supply wires for re-assembly.
7. Connect the *black* wire to the 'gold' screw terminal on the bottom of the lamp socket.
8. Connect the *white* wire to the 'silver' screw terminal on the bottom of the lamp socket.
9. Re-assemble the lamp socket/conduit connector assembly using the same two screws with washers inside of the lamp socket. Make sure that the mounting plate is centered on the lamp socket/conduit connector assembly.
10. Place the lamp socket/conduit connector assembly back into the bottom of the illuminator housing and fasten with the two brass screws.
11. Carefully screw the lamp into the socket and close the illuminator door. Secure by tightening the thumb screw on the side of the housing.
12. Wire the illuminator to the 120 V.* power supply. (*Unless lamp is for 230 V. service) Note that a proper ground wire is recommended.

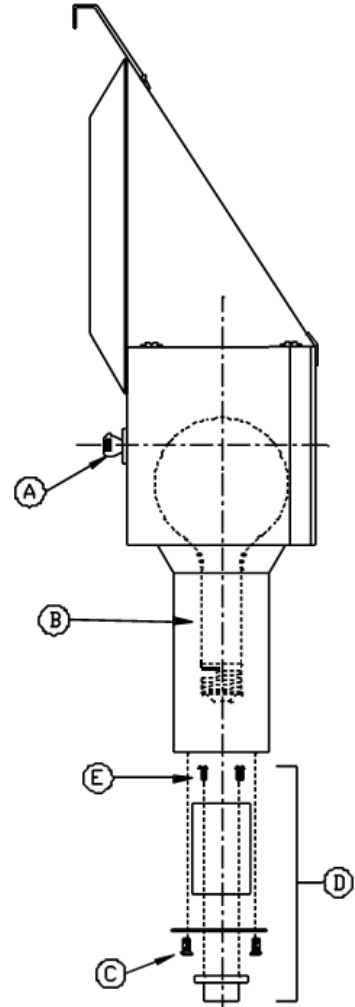

FG*0 Standard Illuminator - 120V.

Specification: 150W/120V

Current Draw: 1.25 Amps

Ernst Flow Industries DrumLite

INTALLATION, OPERATION & MAINTENANCE INSTRUCTIONS

STORAGE and HANDLING

The Ernst Flow Industries DrumLite LED Illuminator meets or exceeds all applicable specifications when shipped from the factory.

All units should be inspected upon receipt to ensure that no damage has been incurred during transit. If there has been, a claim should be filed with the carrier immediately. The unit should be stored in an area protected from the elements and corrosive fumes, in a secure manner where they can neither fall, nor be struck by other objects. Care should be taken to protect the window and the end connections from damage. Avoid placing any objects on the illuminator at any time.

COMPONENTS

There are three main components that make up the DrumLite Illuminator: the light strip with louvers, the power supply, and the cable connecting these two main pieces. The cable may have more than one piece depending on the required distance between the illuminator and the power supply. *Note that an illuminator hood is not required or recommended.*

INSTALLATION

Caution: All lights are tagged with the service conditions for that particular unit. These specifications for that particular unit. These specification are located on the Ernst Flow Industries tag on the power supply housing, and are contained in the "Specifications" section of this manual. Do not sue or refer to specifications listed on the red label on the power supply housing. They are specification for generic use. Review the ratings prior to installation and again prior to start-up, to ensure proper operation in the installed environment. Should there be any doubt as to the applicability of a unit for the installed environment, consult the factory before placing the unit into service.

Note: All installation steps should be performed by a qualified technician and should be executed in accordance with all applicable national and local codes.

The light and power supply should be checked to ensure that they contain no foreign matter, and that the end connections are clean, undamaged, and in line with existing conduit.

Step by step instructions:

1. The upper bracket on the illuminator has two holes that fit onto the hood pins that are installed on the top of the gage glass body. There are two different upper brackets: one for the FG400 and FG900 series gages and another for the FG1500 and FG2000 series gages. Verify that the assembly you received fits the existing gage glass. Slip the upper illuminator bracket on to the hood pins. (See Figure 1)
2. Let the lower bracket rest on the gage glass between the cover plate. Adjust the lower bracket by loosening the set screw and align the bracket at the lowest point on the glass between the cover plate opening. Tighten the set screw to secure the lower bracket.

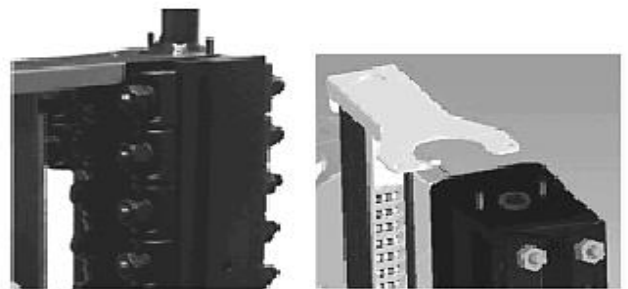
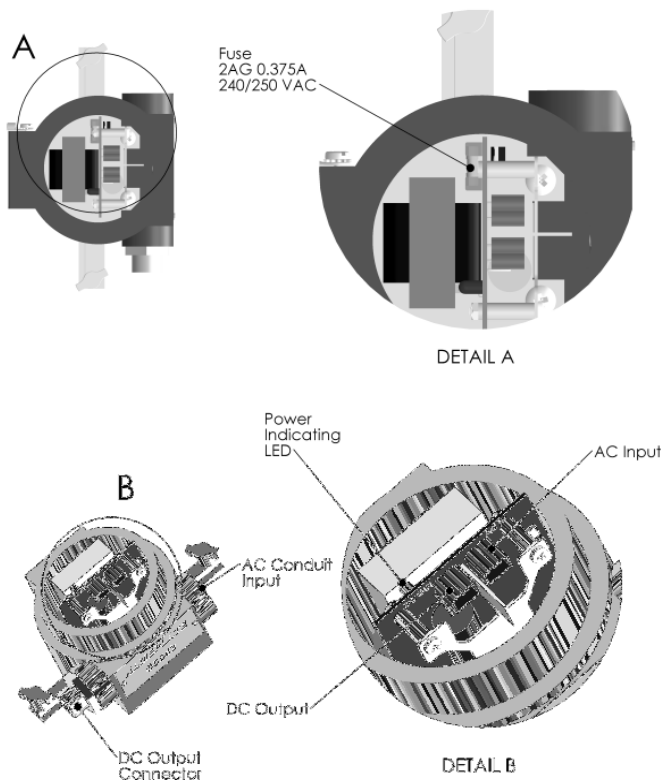

Figure 1

Figure 1 : Wiring Instructions



Caution:
Incorrectly wiring the AC input to the DC output will cause permanent damage to the power supply and could result in ignition of hazardous atmosphere

SPECIFICATIONS

Power Supply: 120 or 240 VAC @ 50-60 Hz
Power Consumption: < 750 mA @ 120 VAC
< 375 mA @ 240 VAC

Est. Life: 100,000 Hours (continuous)

Agency Approvals: FM and CSA
Class I, Div. I Grps. B, C, & D
Class II, Div I, Grps. E, F, & G
Intrinsically Safe Associated Apparatus

Wire Size: Min 18 AWG / Max 12 AWG
Max dist. from power supply to light: 8 feet (2.5M)

Ambient Temperature: -40 F (-40 C) to 170 F (77 C)
Electrical Connection: 3/4" FNPT

RECOMMENDED SPARE PARTS

PRISMATIC GAGE GLASS

Size/Type	Part No.	Description	Quantity
C4 or S4	RK-35	Repair Kit (incl. Glass & Gaskets)	1 per section
C5 or S5	RK-35A	Repair Kit (incl. Glass & Gaskets)	1 per section
C6 or S6	RK-35B	Repair Kit (incl. Glass & Gaskets)	1 per section
C7 or S7	RK-35C	Repair Kit (incl. Glass & Gaskets)	1 per section
C8 or S8	RK-35D	Repair Kit (incl. Glass & Gaskets)	1 per section
C9 or S9	RK-35E	Repair Kit (incl. Glass & Gaskets)	1 per section

FG400 / FG900 SERIES FLAT GAGE GLASS

Size/Type	Part No.	Description	Quantity (Set)
FG404/FG904	RK-4E-SET	Repair Kit Set (incl. Glass, Mica & Gaskets)	1 per section
FG405/FG905	RK-4F-SET	Repair Kit Set (incl. Glass, Mica & Gaskets)	1 per section
FG406/FG906	RK-4A-SET	Repair Kit Set (incl. Glass, Mica & Gaskets)	1 per section
FG407/FG907	RK-4B-SET	Repair Kit Set (incl. Glass, Mica & Gaskets)	1 per section
FG408/FG908	RK-4C-SET	Repair Kit Set (incl. Glass, Mica & Gaskets)	1 per section
FG409/FG909	RK-4D-SET	Repair Kit Set (incl. Glass, Mica & Gaskets)	1 per section

FG1500 SERIES FLAT GAGE GLASS

Size/Type	Part No.	Description	Quantity (Set)
FG1504	RK-5F-SET	Repair Kit Set (incl. Glass, Mica & Gaskets)	1 per section
FG1505	RK-5A-SET	Repair Kit Set (incl. Glass, Mica & Gaskets)	1 per section
FG1506	RK-5B-SET	Repair Kit Set (incl. Glass, Mica & Gaskets)	1 per section
FG1507	RK-5C-SET	Repair Kit Set (incl. Glass, Mica & Gaskets)	1 per section
FG1508	RK-5D-SET	Repair Kit Set (incl. Glass, Mica & Gaskets)	1 per section
FG1509	RK-5E-SET	Repair Kit Set (incl. Glass, Mica & Gaskets)	1 per section

FG2000 SERIES FLAT GAGE GLASS

Size/Type	Part No.	Description	Quantity (Set)
FG2004	RK-38-SET	Repair Kit Set (incl. Glass, Mica & Gaskets)	1 per section
FG2005	RK-39-SET	Repair Kit Set (incl. Glass, Mica & Gaskets)	1 per section
FG2006	RK-40-SET	Repair Kit Set (incl. Glass, Mica & Gaskets)	1 per section
FG2007	RK-41-SET	Repair Kit Set (incl. Glass, Mica & Gaskets)	1 per section

***** REPLACEMENT PARTS WARNING *****

The use of non-Original Equipment Manufacturer parts (such as glass, gaskets, probes, modules, etc.) will void the Agency Approval (FM, UL, CSA, CRN, ABS, etc.), pressure/temperature rating, and warranty of this equipment. Ernst Flow Industries requires the use of OEM parts for all repairs on this product in order to maintain plant and personnel safety, and reliable operation.



VISIT OUR ONLINE STORE:

SHOP.ERNSTFLOW.COM