

GENERAL NOTES:

1. DIMENSIONS
 - SHOWN IN INCHES W/ MM EQUIVALENTS IN BRACKETS
 - OVERALL LENGTH = CENTERS + X + Y
2. OPERATING CONDITIONS
 - MAX PRESSURE & MAX TEMPERATURE REQUIRED FOR PROPER GAGE DESIGN
3. PART NUMBER
 - CONSULT "MAGNicator® II MAGNETIC LIQUID LEVEL INDICATION PRODUCTS" (BULLETIN M100.01) FOR COMPLETE PART NUMBER DETAILS & LIST OF AVAILABLE OPTIONS
 - FOLLOW MAGNicator® II PART NUMBERING FORMAT, REPLACING "MII" WITH "BPC" AND FILLING IN ALL OTHER APPLICABLE INFORMATION
4. STANDPIPE SIZE
 - 3" [80] SCH. 40 (STANDARD)
 - CONSULT FACTORY FOR OPTIONAL STANDPIPE SIZE AND/OR SCHEDULE (DEPENDENT ON OPERATING CONDITIONS)
5. MATERIALS OF CONSTRUCTION
 - CONSULT "MAGNicator® II MAGNETIC LIQUID LEVEL INDICATION PRODUCTS" (BULLETIN M100.01) FOR A COMPLETE LIST OF AVAILABLE MATERIALS (I.E., BYPASS CHAMBERS AVAILABLE IN SAME MATERIALS AS MAGNicator® II)
6. PROCESS CONNECTIONS
 - 1/2" [15] THRU 1" [25] FNPT & MNPT (STANDARD)
 - 1 1/2" [40] THRU 6" [150] FNPT & MNPT AVAILABLE ON REQUEST (REQUIRE FITTINGS THAT INCREASE SECTION A-A DIMENSION SHOWN)
 - (2) SIDE CONNECTIONS (STANDARD)
 - (2+) SIDE CONNECTIONS AVAILABLE ON REQUEST
7. DRAIN CONNECTION
 - 1/2" [15] FNPT (SHOWN) (STANDARD)
 - 1/2" [15] THRU 1 1/2" [40] FNPT, MNPT, FSW, & MSW
 - 1/2" [15] TO 4" [100] RAISED-FACE ANSI/ASME & DIN FLANGED
8. GUIDED WAVE RADAR (GWR) TRANSMITTER
 - WHEN SUPPLIED W/ A GWR TRANSMITTER, THE GWR PROBE LENGTH WILL EXTEND 2" BELOW THE BOTTOM PROCESS CONNECTION
 - TOTAL PROBE LENGTH = CENTERS + 2" + X DIMENSION (SEE TABLE AT TOP OF DRAWING)

OPTION	X
W/O STEAM COMPENSATION	8.000"
W/ STEAM COMPENSATION	18.000"

BILL OF MATERIAL			
NO.	NAME OF PART	MATERIAL	REMARKS
1	STANDPIPE		
2	FLANGE, SLIP-ON		
3	CAP		
4	PLUG		
5	PROCESS CONNECTION		
6	PIPET		

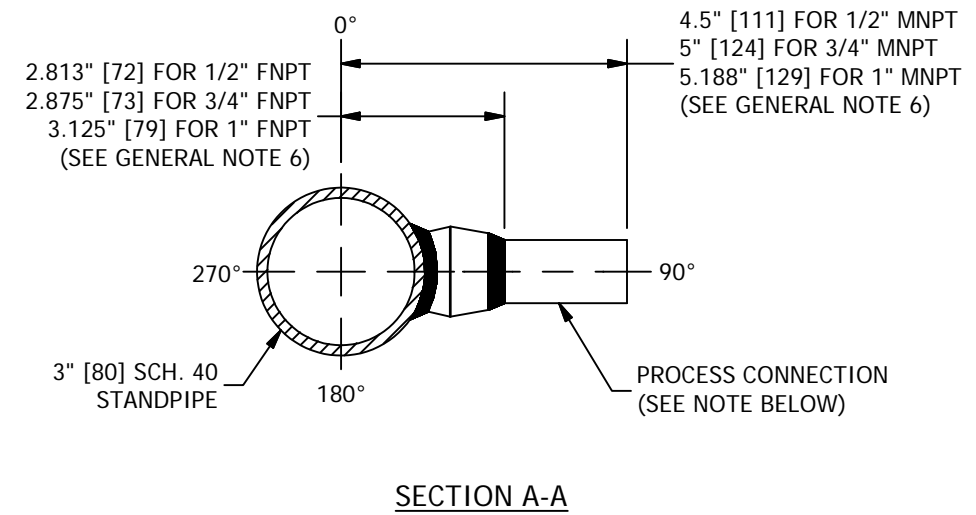
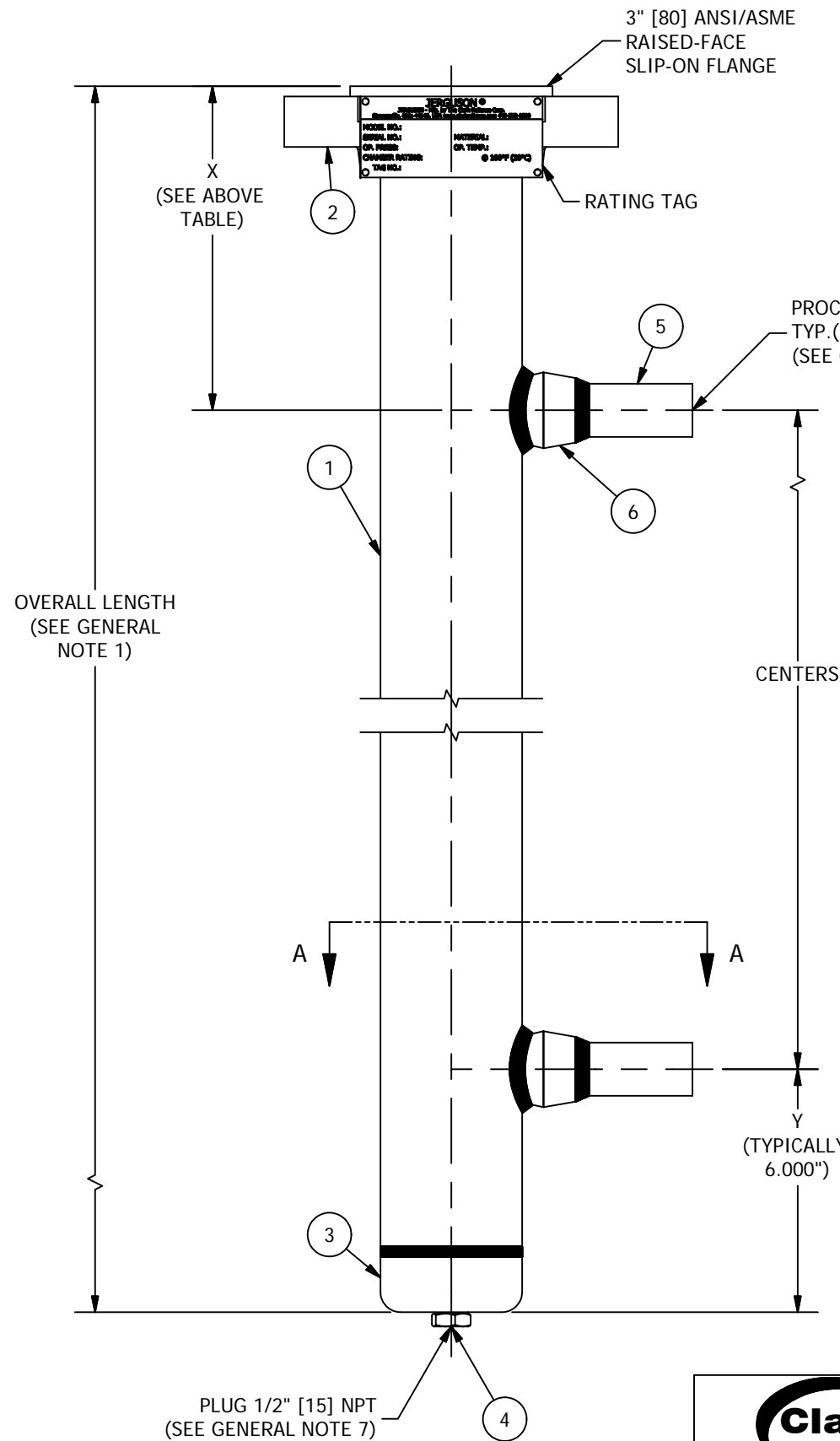

NOTE: AS STANDARD, PROCESS CONNECTIONS WILL BE ORIENTED AT 0° (180° FROM RATING TAG). THEY ARE SHOWN IN THIS DRAWING AT 90° FOR EASE OF VIEWING.

OPERATING CONDITIONS	
MAX PRESSURE	
MAX TEMPERATURE	
PROCESS FLUID	

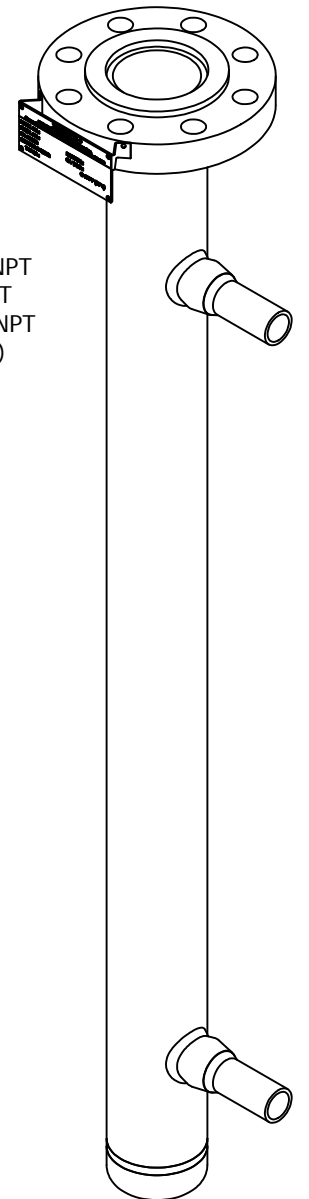

PLUG 1/2" [15] NPT
(SEE GENERAL NOTE 7)

MANUFACTURED BY
Clark-Reliance®
16633 FOLTZ PARKWAY
STRONGSVILLE, OH 44149 USA
(440) 572-1500 | www.clarkreliance.com
© Clark-Reliance® Corporation. All Rights Reserved.

JERGUSON®
MODEL BPC-ST
BYPASS CHAMBER
(W/ 600-2500# ANSI/ASME FLANGES)

DRAWN: SSF	REV.:
CHECKED: MK	
DATE: 4/14/2014	
REVISION: 0	
DRAWING NO.: BPC-ST6	REV.: 0