

The Ultimate Level Switches for **Reliability & Security** for Boiler & Tank Applications

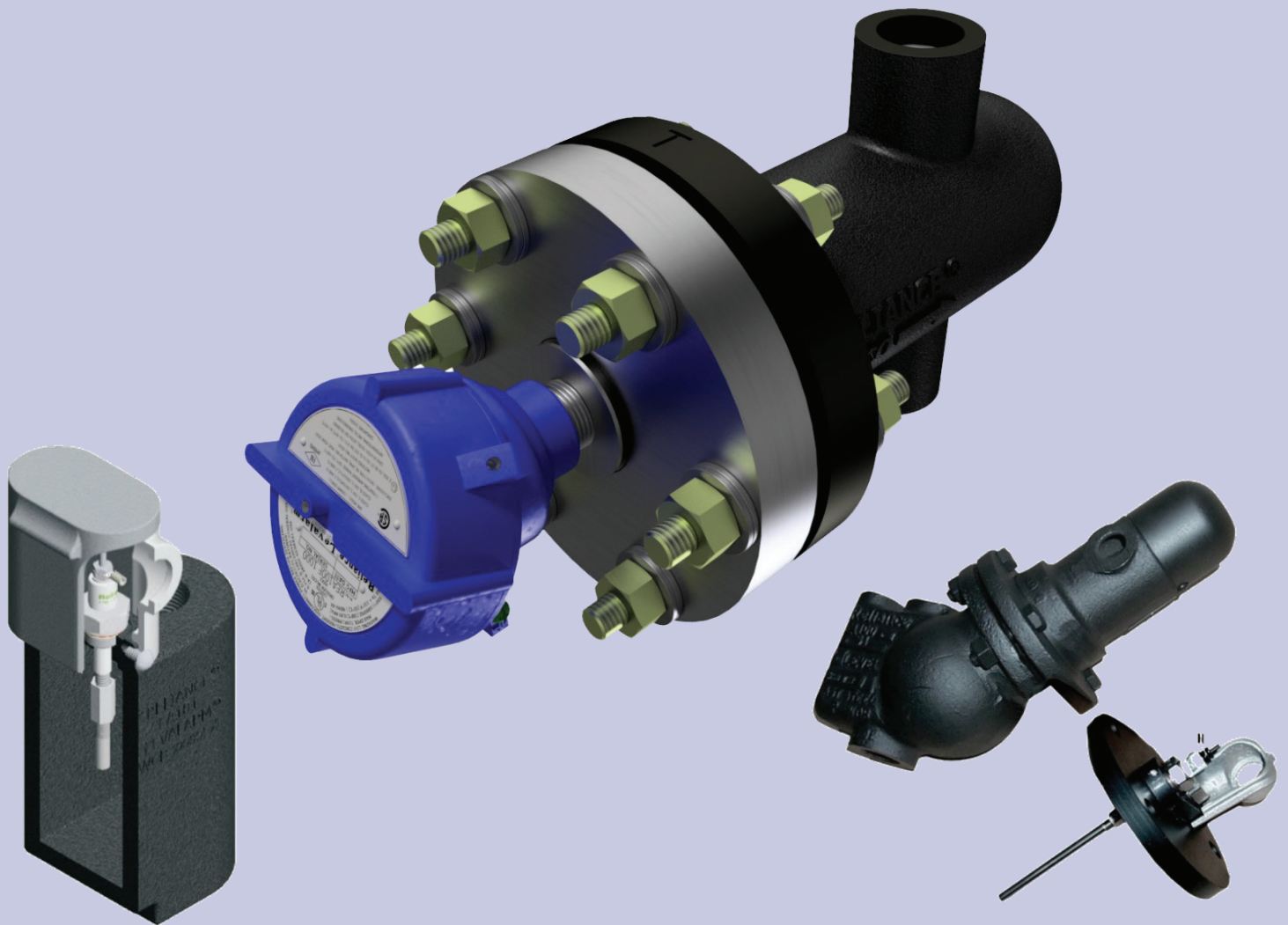

Levalarm®

High/Low Water Alarm Switches
and Fuel Cutouts

Bulletin: D3:1C
Date: 06/2025

Reliance®

A PRODUCT OF CLARK-RELIANCE

The Most Secure Boiler Level Switch

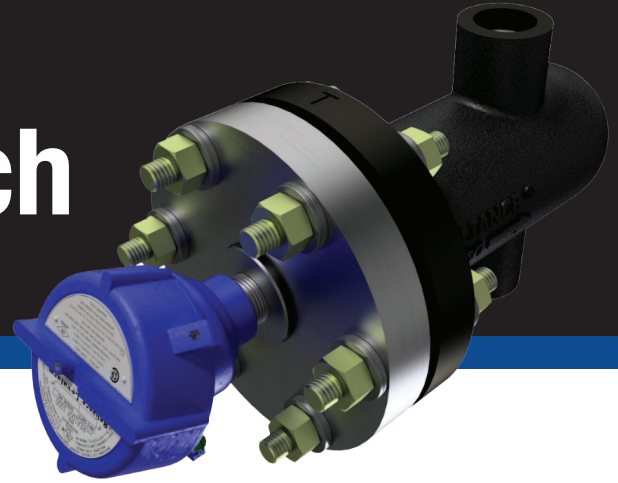

The New Reliance® Levalarm® Float Level Switch

- For pressures up to 1000 PSI
- Zero effect from heat, vibration or loss of electrical power
- Positive interlocking magnet design – proven over decades of use
- Drop-in design requires no adjustments to commission

The Levalarm REA100F-1000 float switch represents a major step forward in reliability. It employs a robust dual magnet design with a positive interlock.

A stainless-steel float is attached to the end of a rod with a stainless-steel encapsulated magnet. The float magnet pivots vertically on an axle inside the chamber. The primary magnet on the float rod drives the secondary magnet located inside the switch housing. The secondary

magnet movement causes a physical activation of a switch. The use of repelling magnetic fields creates a positive interlocking switch that is both vibration resistant and compensates for installation misalignment. A buoyed float will cause the reaction of the magnets to hold the switch open or closed, depending on which terminals are used.

As liquid falls in the chamber, the float drops and directs the magnets to the opposite position which activates the switch.

Repelling magnetic fields provide positive, rock-solid operation no matter how much vibration or heat.

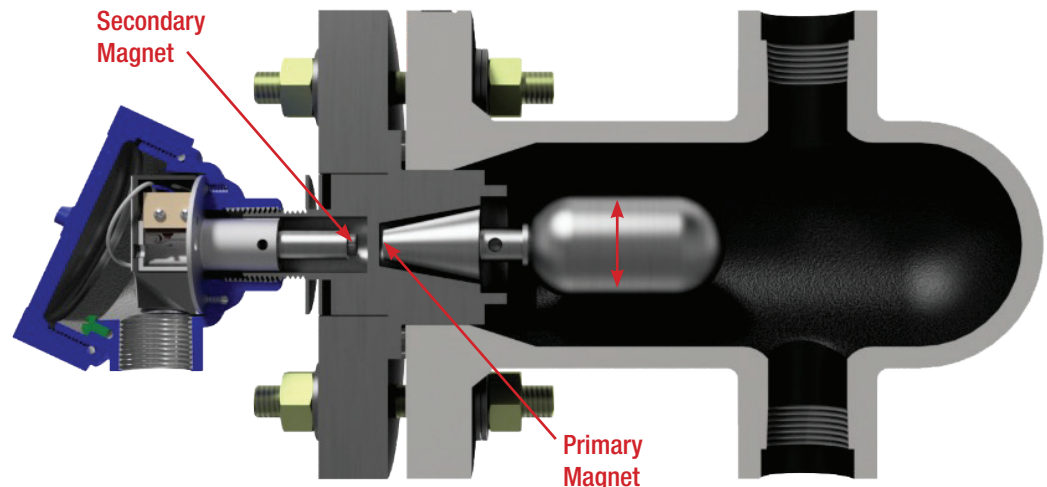

One Compact Float Model to Suit All of Your Boiler Applications

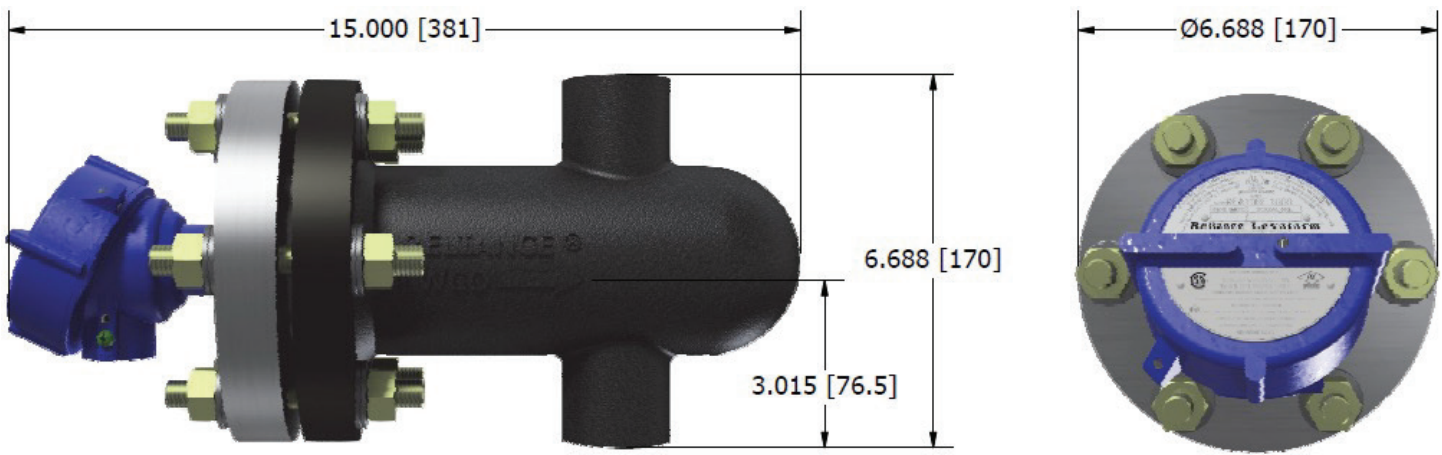

Weight = 33 lb [15 kg]

Model Dimensions – Inches [millimeter]

Agency Approvals/Ratings

UL 60730 and CRN OH16066 for all Provinces

- Electrical: 0.75A @ 120/240VAC General Use
1.00 A @ 28VDC General Use
(Both Instances tested to 100k Cycles)
- Max Operating Ambient: 131°F [55°C]
- Certified to NEMA 4X Rating

Process Connection Size

1" Female Socket Weld with interior 1" FNPT Pipe Connections

**Maximum Operating Conditions
(MAWP = Maximum Allowable Working Pressure)**

1000 PSI [69 Bar] MAWP @ 546°F [285°C]

MicroSwitch Rating

UL, CE, CSA approved SPDT
11A @ 125/250 VAC
5A @ 30 VDC; 1/2A @ 125 VDC

Enclosure Rating

FM/CSA/ATEX/IECEX Explosion Proof Certified
3/4" Conduit Connection
Nema 4X and IP66/68

Environment

Indoor or outdoor

Probe-Type Level Switches for Pressures up to 1800 WSP (124 Bar)



Series REA101

- Dual functions on boilers and tanks
- Recommended control for power plants and processing facilities

Series REA101 models provide reliable and instant response. Probes respond to the rise and fall of water at pre-determined points, to actuate a variety of controls. Each Levelarm monitors up to 3-inch level variation. Multiple units, in series, extend the monitoring range. Use almost anywhere on water applications.

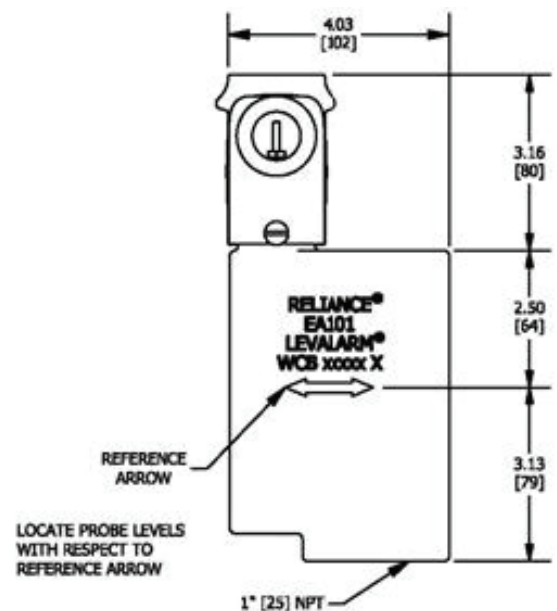
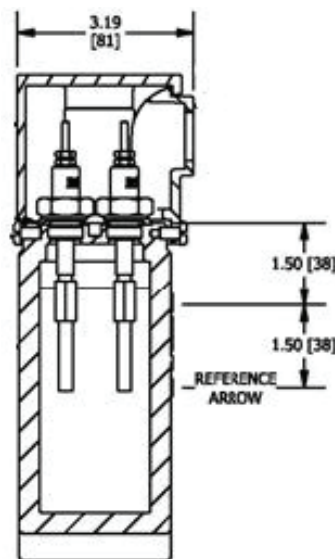
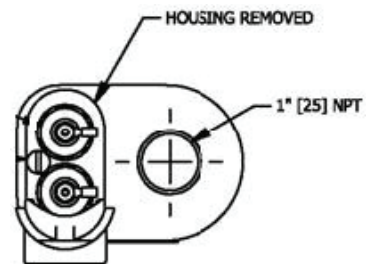

Standard Models with a Single Probe

- Model REA101D-T030 up to 350 psi (24 Bar)
- Model REA101S-V030 up to 1000 psi (69 Bar)
- Model REA101S-Z030 up to 1200 psi (82.75 Bar)
- Model REA101SW-Z030 up to 1800 psi (124 Bar)

Note: For installations in Canada, use Model REL450-1WP, REL1000-1WP, REL1800-1WP. Consult factory for details.

A Full Line of Reliance RECID Relay Controls

Relay Control Modules

- Each relay control module is independently fuse protected
- Plug-in relay modules are removed by hand, no tools required
- Relays supply low voltage (12VAC) to probes
- Relays enhance sensitivity or extremely low water conductivity applications, to 1 MicroMho
- Relays improve switch contact reliability for low load applications, such as a computer interface or recorders
- Relays use integral red LED indicators to verify status
- Relays will retrofit existing system installations

Direct Mode Operation (Standard)

When water level rises to Terminal 3 Probe, water completes circuit. Circuit signals relay to change state of load contacts, activating alarm or other equipment, while illuminating the integral LED. Relay is energized until water drops below the probe to break circuit, turning off alarm and LED.

Inverse Mode Operation (Optional)

Upon powering supply terminals 1 and 2, relay energizes (LED on). When water rises to terminal 3 probe, probe signals relay to de-energize (LED off). Relay remains de-energized until water drops below the probe. Relay remains in "safe" mode in low level applications. Specify inverse mode when required.



Relay Control Unit with Enclosure



RECID-23R Relay Module



RECID-49 Surface Mount
Socket for Relay Module

From the **World's Largest Selection** of Boiler Instrumentation and Control Devices



Eye-Hye® SmartLevel™
Local and Remote Indicators

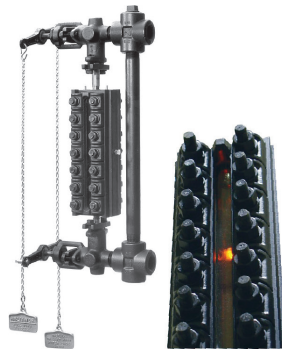

Flat Glass Gages
and **DuraStar™** Illuminators



LevelMax
Systems



Simpliport® 180
Water Gage System



Levalarm®
Boiler Level Switches

Maintain Optimal Performance and Accuracy with OEM Parts
Critical spare parts for overnight delivery, direct from the manufacturer.



parts.clark-reliance.com

