

Simpliport® Illuminator

for
Hazardous Locations



Reliance®
A PRODUCT OF CLARK-RELIANCE

STORAGE and HANDLING

The Reliance® Simpliport® Explosion Proof Illuminator meets or exceeds all applicable specifications when shipped from the factory.

All units should be inspected upon receipt to ensure that no damage has been incurred during transit. If there has been damage, a claim should be filed with the carrier immediately. Unit should be stored in an area protected from the elements and corrosive fumes, in a secure manner where they can neither fall, nor be struck by other objects. Care should be taken to protect the window and the end connections from damage. Avoid placing any objects directly on the light at any time.

COMPONENTS

There are three main components that make up the LED illuminator: the light strip, power supply, and cable connecting these two main pieces. The cable may have more than one piece depending on the required distance between the illuminator and power supply. Questions regarding acceptable applications should be directed to The Clark-Reliance® Corporation.

ELECTRICAL CONNECTION

CAUTION: All lights are tagged with the service conditions for that particular unit. These specifications are located on the Reliance® tag on the power supply housing, and are contained in the “Specifications” section of this manual. Review the ratings prior to installation and again prior to start-up.

Note: All installation steps should be performed by a qualified technician and should be executed in accordance with all applicable national and local codes.

The light and power supply should be checked to ensure that they contain no foreign matter, and that the end connections are clean and undamaged.

NOTE: If desired, the light may be installed onto the glass gauge prior to connecting electrical.

CAUTION: Before working with power supply, verify that the area is free of flammables and AC power circuit is off.

- 1) Open the cover of the power supply housing. Insert the AC Line wires into the housing and connect to the “AC IN” terminal block. Ground screws are located inside and outside the enclosure. **CAUTION:** The DC output is pre-wired. If this connection is removed during installation, reconnect the “AC IN” and “DC OUT” to the proper positions. Failure to do so will result in permanent damage to the power supply. (Ref. Fig.3, pg5)
- 2) If the cable will not reach the power supply, contact your local representative for the required extension cable.
- 3) Replace the cover on the power supply housing.
- 4) Switch “ON” the power supply making sure the Illuminator is functioning properly, with all LED’s illuminated.
- 5) Refer to the troubleshooting section in this manual if a portion or all of the LEDs do not illuminate.

ROUTINE MAINTENANCE

Keep lenses on the front of the light clean using commercial glass cleaners, such as Windex® or similar. Never use harsh abrasives, wire brushes, metal scrapers, or any material that could scratch the window. The lenses may be cleaned while the unit is in operation.



Typical Simpliport® LED Illuminator Installation

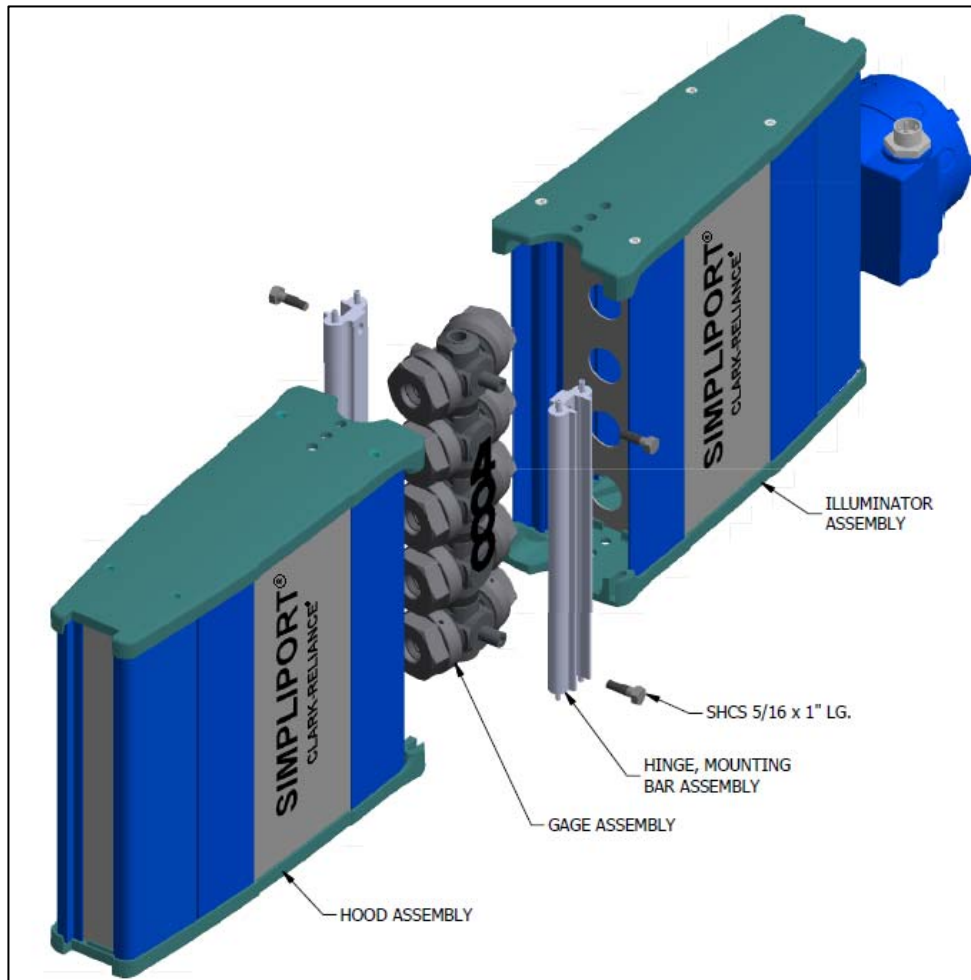

Figure 1

Viewing the Gage

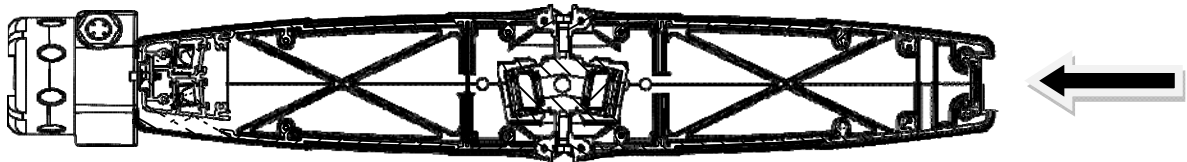

Figure 2

Reliance®
A PRODUCT OF CLARK-RELIANCE

SPECIFICATIONS

Power Supply:	130 or 230 VAC @ 50-60 Hz
Power Consumption:	< 750 mA @ 120 VAC < 375 mA @ 240 VAC
Est. Life:	100,000 Hours (continuous)
Approvals:	FM Class I, Div. 1 Groups B, C, D T4 CSA Class I, Div. 1 Groups B, C, D T4 Associated Equipment [Exia]
Ambient Temp:	-40 F (-40 C) to 170 F (77 C)
Wire Size:	Min 18 AWG / Max 12 AWG
Max dist. power supply to light:	72 feet (22M)
Electrical Connection:	¾" FNPT

Reliance® Simpliport® Illuminator Spare/Replacement Parts	
Description	P/N
115 VAC FM / CSA Power Supply Board / Bracket Sub-Assembly	S23293
230 VAC FM / CSA Power Supply Board / Bracket Sub-Assembly	S23294
Fuse (400 mA, Ceramic Cartridge, ATEX Certified)	E-F-DIN-F400MA (4 Fuses)
18" Cable w/ 90 degree Connector	V20509
6-1/2 foot (2 meter) Extension Cable (for Remote Mounting)	V20601-6.5
2-1/2 foot (.75 meter) Daisy-Chain Cable	V20601
M20 metric brass adaptor (3/4"MNPT x M20 female)	V19705-F



Troubleshooting

Description of Problem	Possible Cause	Troubleshooting Procedure
All LEDs out	No AC line voltage Blown Fuse Loose or disconnected DC output wires Blue Power Cord loose or connector damaged Loose or damaged connections inside LED Assembly Damaged Power Supply	Follow troubleshooting steps below
Set or sets of LEDs out	Defective LED Board	Contact Factory
LEDs out above a certain point	Loose connection between LED boards Defective LED board	Contact Factory
LEDs out in group (more than 4)	Defective LED board	Contact Factory

Troubleshooting Steps

Caution: Some of these troubleshooting steps are performed with live voltage applied. The assembly should be moved to a safe area before beginning work. A qualified and properly trained technician must perform these steps.

NOTE: See Figure 1 on next page for component locations.

- 1) Remove enclosure cover and look to see if red LED power indicator is on.
 - a) If red LED is on, go too step 4.
- 2) Check AC wiring to make sure it is properly installed and tightened in connector.
- 3) Using a meter, verify AC line voltage at AC connector.
- 4) Disconnect AC power. Using a small pair of needle-nose pliers, gently remove fuse from holder.
- 5) Check fuse for continuity with an Ohm meter. If there is continuity, re-install fuse. If there is no continuity, replace fuse.
- 6) Check DC output wiring to make sure it is properly installed and tightened.
- 7) Reconnect AC power.
- 8) Using a voltmeter set to DC; measure the voltage across the output connector. Voltage should be between 9VDC and 15VDC.
- 9) Unscrew and remove blue power cord. Inspect the 4 pins inside end connector to make sure they are straight and undamaged. If pins are bent, use a small pair of needle-nose pliers to straighten bent pins. If pins are missing, contact factory.
- 10) Reconnect power cord making sure connectors are fully seated and tightened.
- 11) If all steps above check OK, contact factory for support.



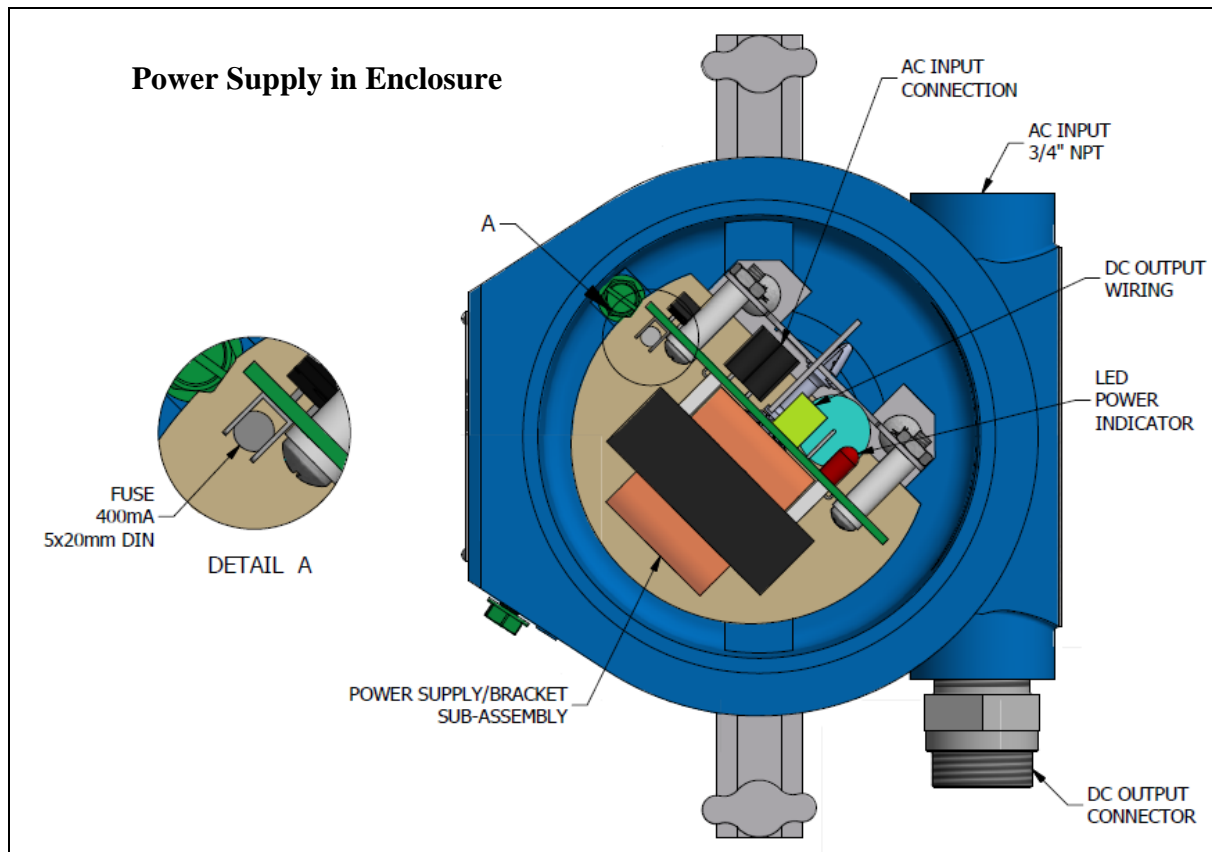

Figure 3

REPLACEMENT OF POWER SUPPLY SUB ASSEMBLY

(P/N S23293 and S23294)

NOTE: Make sure AC power is off before removing cover.

- 1) Loosen cover locking screw and open the cover of the power supply housing. Disconnect AC power and remove AC wires from enclosure.
- 2) Remove assembly from gage and relocate to desired work area.
- 3) Unplug DC power plug.
- 4) Remove 2 screws holding power supply sub assembly in place.
NOTE: Screws are installed with Loctite. If screws will not come loose, sharply hit the back of the screwdriver with a hammer to help release the hold of the Loctite.
- 5) Place new power supply into position in the enclosure, apply permanent liquid thread lock to the screws and reinstall screws.
- 6) Re-connect DC power plug and bench test unit by applying AC through the AC Input Connector (ref. Figure 1).
- 7) Re-install on gage and reconnect AC power.

Reliance®
A PRODUCT OF CLARK-RELIANCE

NOTES:

Reliance[®]
A PRODUCT OF CLARK-RELIANCE



On-Line Parts – DIRECT – for Clark-Reliance Products

JERGUSON® **Reliance®**

JACOBY-TARBOX® **MAGNE-SONICS®**



www.clark-reliance.com/parts

Reliance®
A PRODUCT OF CLARK-RELIANCE