

# Magnicator® II

Magnetic Liquid Level Indication Products

## SPECIFICATION GUIDE



**JERGUSON®**

A PRODUCT OF CLARK-RELIANCE

## Contents

<b>Magnicator® II Model MII Specifications</b>	<b>3</b>
Chamber & Materials	4
Vent/Drain and Process Connections	5
Process Conditions, Indicator & Scale	6
Options	7
Chamber Style Illustrations	8
<b>Magnicator® II Model MGWRS Specifications</b>	<b>9</b>
Chamber & Materials	10
Vent/Drain and Process Connections	11
Process Conditions, Indicator & Scale	12
Options	13
Chamber Style Illustrations	14
<b>Magnicator® II Model MGWRD Specifications</b>	<b>15</b>
Chambers & Materials	16
Vent/Drain and Process Connections	17
Process Conditions, Indicator & Scale	18
Options	19
Chamber Style Illustrations	20
<b>Magnicator® II Model BPC Specifications</b>	<b>21</b>
Chamber & Materials	22
Vent/Drain and Process Connections	23
Process Conditions & Options	24
Chamber Style Illustrations	25
<b>Vent &amp; Drain Style Illustrations</b>	<b>26</b>
<b>Discover a World of Solutions</b>	<b>27</b>

# MAGNICATOR® II Specification Guide

## *Model MII*





See Page 5  
Define Vent/  
Drain and  
Process  
Connections

See Page 6  
Define  
Process  
Conditions /  
Indicator  
and Scale

See Page 8 Options

### CHAMBER DESIGN

Code	Description
MII	Standard, ASME B31.3 Design
MIIF	Flashproof, ASME B31.3 Design

### NOMINAL CHAMBER

#### SIZE

Code	Description	Valid w/Chamber Design
15	1.50" NPS	MII
20	2.0" NPS	MII
25	2.5" NPS	MII
30	3.0" NPS	MII, MIIF

### FLANGE CLASS

Code	Description	Code	Description
01	150# ASME	D10 <sup>2</sup>	DIN PN 10
03	300# ASME	D16 <sup>2</sup>	DIN PN 16
06	600# ASME	D25 <sup>2</sup>	DIN PN 25

Yellow shading indicates standard offering. Standard products are the most economical and have the fastest deliveries.

### SCHEDULE

Code	Description	Valid w/ Chamber Design/Size
B	Sched. 10	MII-15, 20 <sup>1</sup> , or 25 <sup>1</sup>
C	Sched. 40	MII-20, 25, or 30   MIIF-30
D	Sched. 80	MII-25 or 30   MIIF-30
E	Sched. 160	MII-30

### MATERIAL(S) OF CONSTRUCTION (Standpipe Material/Trim Material<sup>3</sup>)

Code	Description	Code	Description
R <sup>4,5</sup>	304/304L Stainless Steel	MD13 <sup>7</sup>	Incoloy® 800
RA <sup>5</sup>	304/Carbon Steel <sup>3</sup>	MD14 <sup>7</sup>	Inconel® 625
T	316/316L Stainless Steel	MD15 <sup>7</sup>	Incoloy® 825
TA	316/Carbon Steel <sup>3</sup>	XL4 <sup>7</sup>	SMO 254, UNS 31254
K <sup>7</sup>	Alloy 20	ZZ <sup>7</sup>	Zirconium ZR2
LC <sup>7</sup>	Hastelloy® C276	PFR <sup>8</sup>	PFA Teflon® Coated 304/304L SS
N <sup>7</sup>	Monel® 400	PFT <sup>8</sup>	PFA Teflon® Coated 316/316L SS
S <sup>7</sup>	347 Stainless Steel	PVR <sup>8</sup>	PVDF® Coated 304/304L SS
Y <sup>7</sup>	321 Stainless Steel	PVT <sup>8</sup>	PVDF® Coated 316/316L SS
V <sup>7</sup>	317 Stainless Steel	HLR <sup>9</sup>	HALAR® Coated 304/304L SS
TT <sup>7</sup>	Titanium	HLT <sup>9</sup>	HALAR® Coated 316/316L SS
LB3 <sup>7</sup>	Hastelloy® B3	CP <sup>8,9</sup>	CPVC Construction (Includes Float)
MD4 <sup>7</sup>	Inconel® 600	PV <sup>8,10</sup>	PVDF® Construction (Includes Float)

### CHAMBER STYLE<sup>11</sup> (See Page 8 for Illustrations)

Code	Top End of Chamber	Bottom End of Chamber
CM	Welded Cap	Flange with Mating Flange
MC	Flange with Mating Flange	Welded Cap
MM	Flange with Mating Flange	Flange with Mating Flange
MF	Flange with Mating Flange	Flange
FM	Flange	Flange with Mating Flange
CF	Welded Cap	Flange
FC	Flange	Welded Cap
FF	Flange	Flange
CT <sup>12</sup>	Welded Cap	Welded Cap w/ Thread (Chamber Access)
TC <sup>12</sup>	Welded Cap w/ Thread (Chamber Access)	Welded Cap
TT <sup>12</sup>	Welded Cap w/ Thread (Chamber Access)	Welded Cap w/ Thread (Chamber Access)
B0 <sup>7,13</sup>	Top Mount (BEF) without Stilling Well or Guide Pipe (If Inserted Into Existing Pipe or Stilling Well)	
B1 <sup>7,13</sup>	Top Mount (BEF) with Guide Pipe (Insertion Lengths Up To 24" (610mm), or Stilling Well Fit Issues)	
B2 <sup>7,13</sup>	Top Mount (BEF) with Open-Ended Stilling Well (Insertion Lengths 24" (610mm) & Over)	
B3 <sup>7,13</sup>	Top Mount (BEF) with Capped Stilling Well (Insertion Lengths 24" (610mm) & Over)	

# MAGNICATOR® II Specification Guide – Model MII

## Define Vent/Drain & Process Connections

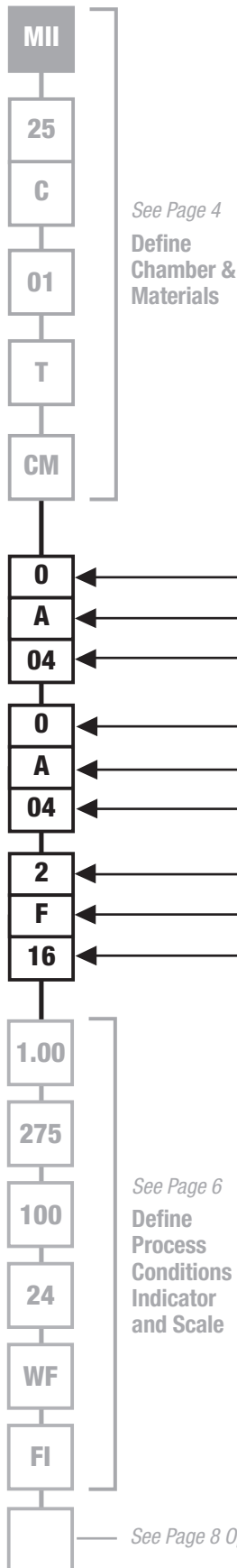

### VENT/TOP CHAMBER CONNECTION<sup>16, 17</sup> (See Page 26 for Illustration)

VALVE		STYLE <sup>21</sup>		SIZE	
Code	Description	Code	Description	Code	Description
0	None	A	FNPT (Female NPT)	04	1/2" (DN 15)
1	Gate	B	FSW (Female Socket Weld)	06	3/4" (DN 20)
2	Globe	C	MNPT (Male NPT)	08	1" (DN 25)
S	Spl/Custom Specified	D	MSW (Male Socket Weld)	12	1-1/2" (DN 40)
		F <sup>11</sup>	Flange	16	2" (DN 50)
		K	None	20	2-1/2" (DN 65)
				24	3" (DN 80)
				00	N/A
					Valid w/ Connection Style

### DRAIN/BOTTOM CHAMBER CONNECTION<sup>18, 19</sup> (See Page 26 for Illustration)

VALVE		STYLE <sup>21</sup>		SIZE	
Code	Description	Code	Description	Code	Description
0	None	A	FNPT (Female NPT)	04	1/2" (DN 15)
1	Gate	B	FSW (Female Socket Weld)	06	3/4" (DN 20)
2	Globe	C	MNPT (Male NPT)	08	1" (DN 25)
S	Spl/Custom Specified	D	MSW (Male Socket Weld)	12	1-1/2" (DN 40)
		F <sup>11</sup>	Flange	16	2" (DN 50)
		K	None	20	2-1/2" (DN 65)
				24	3" (DN 80)
				32	4" (DN 100)
				00	N/A
					Valid w/ Connection Style

### SIDE PROCESS CONNECTION(S)

NO. OF SIDE CONNECTIONS		STYLE <sup>21</sup>		SIZE	
Code	Description	Code	Description	Code	Description
0	No Side Connections	A	FNPT (Female NPT)	04	1/2" (DN 15)
1T	1 @ Top Side Only	B	FSW (Female Socket Weld)	06	3/4" (DN 20)
1B	1 @ Bottom Side Only	C	MNPT (Male NPT)	08	1" (DN 25)
2	2 Side Connections	D	MSW (Male Socket Weld)	12	1-1/2" (DN 40)
# <sup>22</sup>	3+ Side Connections ('#', Specify Qty)	E	Butt-Weld	16	2" (DN 50)
		F <sup>11</sup>	Flange	24	3" (DN 80)
		K	None	00	N/A

#### Notes:

- Coated chamber materials only.
- Applicable only to flanged, customer facing connection(s); process, vent, drain.
- 'Trim' is any chamber component(s) above/below the standpipe, & any process flange(s).
- Chamber cap is 316/316L SS.
- Guide bars (when flashproof) are 316/316L SS.
- Consult factory for chamber size & schedule code.
- Coated, CPVC or PVDF chamber materials not available w/ Flashproof design.
- Model MII-25C-01 only.
- Model MII-20C-01 only.
- Metallic (& when available, Coated) Mat'l's: Raised-face flange std. Slip-On 150#-600#. Weld Neck 900# & up. Plastic: Socket-weld flange std. Std faces raised and/or flat (uncontrolled, at vendors' discretion).
- Only available with Nominal Chamber Size '15'.
- Requires completed BEF specification form, M200.07; prior to quoting.
- Valve & Style selections shall be '0F', for Chamber Style 'F(M, C, or F)'.<sup>20</sup>
- Nominal Chamber Size '15', requires Valve, Style, & Size selections to be '0A16', for Chamber Style 'T(C or T)'.<sup>20</sup>
- Valve & Style selections shall be '0F', for Chamber Style '(M, C, or F)' or 'B(0,1, or 2)'.<sup>20</sup>
- Nominal Chamber Size '15', requires Valve, Style, & Size selections to be '0A16', for Chamber Style '(C or T)'.<sup>20</sup>
- Flange Size shall be greater than or equal to Nominal Chamber Size.
- For coated chambers, all connections flanged.
- Specify elevation(s) of intermediate nozzle(s).
- Contact factory for additional application guidance.
- (a) A multiple section chamber may be required when range/center exceeds mat'l/ application limits; ~225" metallic & CPVC, ~175" PVDF, ~100" coated. Each joint shall be flanged, have a break in the measuring range, include support/lifting brackets on either side. Consult factory for continuous chamber options.
- (b) For CPVC & PVDF gages, support brackets, option BR#, recommended every ~84" (2134mm).
- (c) For gages w/ 1+ end process connection(s), consult factory for resulting visible range, or process connection dimension.
- Additional air purge kit (1/8" FNPT connection) available, up to 600°F (315°C) max. NEMA 4X rating no longer applicable.
- Two scales on indicator, along either side (left/right) of flags. Not available on NightStar indicators.
- Not all options are available w/ every combination. Unless already identified, consult factory for applicability.
- May result in 1" increase/decrease in chamber float leg/ visible range, respectively.
- Not applicable w/ CPVC or PVDF.
- Located in-line w/ upper-side branch conn. (when present, otherwise 180° from indicator), unless otherwise noted.
- Raw mat'l of all wetted piping components from USA, Canada, Japan, or W. Europe (as defined by C-R)
- Standard dimensions listed. Subject to change based on actual design.
- Meets B31.3 & NACE, w/ or w/o Insulation.
- Suitable only for 150#/300# flanged joints, w/o a spiral wound gasket.
- Indicator location (in degrees) clockwise from top-side process, viewed from above the gage. N/A for 180° (std) or zero side connections.



# Define Process Conditions/Indicator & Scale

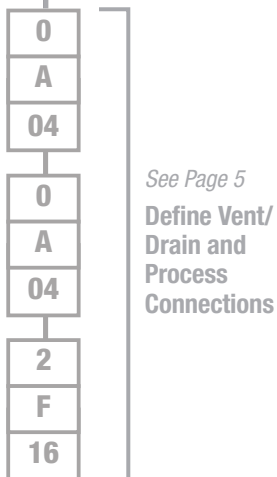
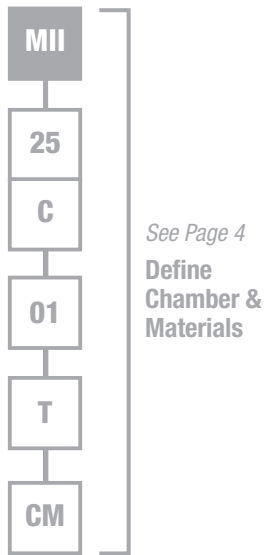

See Page 7 Options

**SPECIFIC GRAVITY** 0.30 & Up, Depending on Float Style & Max Operating Conditions. For varying SG applications, specify min SG in the range. For interface applications,<sup>24</sup> specify "Upper Fluid"/"Lower Fluid" (0.1 Min Differential Req'd).

**MAXIMUM OPERATING PRESSURE (PSIG)** Up to 3500 psig (241 bar); Consult factory for greater values.

**MAXIMUM OPERATING TEMPERATURE (°F)** Up to 1000°F (537°C) max.

**VISIBLE RANGE / CENTER-CENTER or FACE-FACE or CENTER-FACE<sup>25</sup>**  
Enter (1) value if visible range & center-to-center are equal. Exact inches (for mm, add "mm").

**FLAG STYLE INDICATOR**

Yellow (Liquid)/Black (Vapor) Colors Standard. See Options for Red/White Order Code. Consult Factory for Other Color Options.

Code	Description
WF	Wide Indicator (1-1/2" Flag), Sealed (NEMA 4X) in Anodized Aluminum Housing, 1000°F (537°C) Max
HWFP	Wide Indicator (1-1/2" Flag), Hermetically Sealed (IP68) in Polycarbonate Tube, Stainless Steel Frame, 500°F (260°C) Max
FL	Conventional Indicator (3/4" Flag), Sealed (NEMA 4X) in Anodized Aluminum Housing, 1000°F (537°C) Max
HFLP	Conventional Indicator (3/4" Flag), Hermetically Sealed (IP68) in Polycarbonate Tube, Stainless Steel Frame, 500°F (260°C) Max
HFLG	Conventional Indicator (3/4" Flag), Hermetically Sealed (IP68) in Glass Tube, Stainless Steel Frame, 1000°F (537°C) Max (Sealed Glass Tube Sections Stacked End to End w/ ~1.5" (38mm) Gap, when Visible Exceeds 78" (1981mm))
N### <sup>26</sup>	NightStar™ (USA/CAN) Illuminated Conventional Indicator (3/4" Flag), Sealed (NEMA 4X) in Anodized Aluminum Housing, 450°F (232°C) Max ('###' = Supply Power, VAC (i.e., N120 or N240))
NX### <sup>26</sup>	NightStar™ (ATEX/IECEX) Illuminated Conventional Indicator (3/4" Flag), Sealed (NEMA 4X) in Anodized Aluminum Housing, 450°F (232°C) Max ('###' = Supply Power, VAC (i.e., NX120 or NX240))
NI	No Indicator

**SCALE TYPE**

Code	Description
FI	Feet/Inches
MM	Meter/Millimeter
PS	Percent Scale
SS	Special Scale
NS	No Scale
_/_	Dual Scale <sup>27</sup> Format, Specify Types (Example: FI/MM)

# MAGNICATOR® II Specification Guide – Model MII

## Define Options

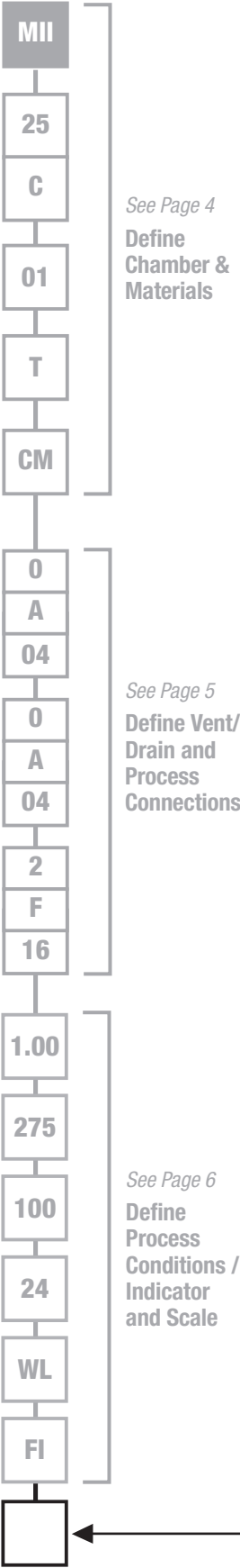

**OPTIONS<sup>28</sup>** To define multiple options, add additional codes as suffixes to model string.

Code	Description
<b>RW</b>	Red (Liquid) /White (Vapor) Flag Indicator Colors (Std is Yellow/Black)
<b>SF<sup>29</sup></b>	Sunken Float Indicator (1" Below Measuring Range, w/ Alternate Flag Color Indication)
<b>DI<sup>24</sup></b>	Dual Indication, Total Level & Interface (WF Series or Hermetic Indicators Only. Both SG's Req'd.)
<b>SW<sup>30</sup></b>	Socket-Weld Flanges (All Around, Up To & Including 600#, Consult Factory above 600#)
<b>WN</b>	Weld Neck Flanges (All Around, Up to & Including 600#. Std. above 600#)
<b>BW</b>	Butt Weld Construction (Includes Full Bore Butt Weld Tees @ Branch Connections, & WN Flanges)
<b>BR#<sup>31</sup></b>	Support Bracket(s) (# = No. of Brackets. Unless Otherwise Noted, Evenly Spaced Between Process Connections)
<b>NF</b>	Non-Frost Extension, 3-5/8" (92mm) Depth (Min. Temp. -300°F (-184°C))
<b>CI</b>	Cold Insulation, 2" (50mm) Nominal Rigid Foam w/ Alum Jacket, -297°F (-182°C) to 300°F (148°C). Non-Frost (NF) Ext Included.
<b>ST</b>	Steam Tracing, 3/8" (9.5mm) OD Tube with Compression Fitting
<b>E11</b>	Self-Regulating, 120VAC Electric Heat Trace, Cl.I, D1, Grps B,C,D. Consult Factory for Optional Thermostat.
<b>E12</b>	Self-Regulating, 120VAC Electric Heat Trace, Cl.I, D2, Grps B,C,D, NEMA 4X Enclosure. Consult Factory for Optional Thermostat.
<b>HI</b>	High Temperature Insulation, Flexible Jacket, 500°F (260°C)
<b>HI8</b>	High Temperature Insulation, Flexible Jacket, 800°F (426°C)
<b>BC</b>	Designed to ASME Section I Boiler Code, 900 PSIG Max. Oper. Press. (Refer to Boiler Code Bulletin)
<b>NC</b>	NACE Compliant to MR0103/0175
<b>RMW<sup>32</sup></b>	Regionally Restricted Material
<b>B1</b>	Designed to ASME B31.1
<b>GR</b>	Flexible Graphite Gasket w/ 316 Stainless Steel Insert
<b>SWG</b>	Spiral Wound Gasket (Graphite Filler w/ Inner Ring & Windings To Match Chamber) (Std w/ 600# Class Flanges & Above)
<b>RJ</b>	Ring Joint Flanges (All Around)
<b>MT</b>	Magnetic Trap, In-Line w/ Bottom-Side Process Connection
<b>SE<sup>30</sup></b>	Stub End w/ Lap Joint (aka: 2-Piece) Process Flange (Up To & Including 600#)
<b>SP#</b>	Set Point Arrow(s) (# = No. of Arrows, Evenly Spaced Along Indicator, unless otherwise noted)
<b>SJ<sup>33</sup></b>	Steam Jacketed w/ 1/2" FNPT (Std) (Jacket Length = Process C/L minus 7" (178mm), Jacket C-C = Process C/L minus 12" (305mm))
<b>SML</b>	Seamless Pipe
<b>S8</b>	Schedule 80 Nipples/Fittings (Does not apply to 1) Chamber, 2) Flange Class 600# & up (Std))
<b>S16</b>	Schedule 160 Nipples/Fittings (Does not apply to Chamber)
<b>B7M<sup>34</sup></b>	Cr-Mo Bolting (ASME A193 Gr.B7M Studs & ASME A194 Gr.2HM Nuts)
<b>B8M<sup>35</sup></b>	316SS Bolting (ASME A193 Gr.B8M, Class 1 Studs & ASME A194 Gr.8MA Nuts)
<b>I###<sup>36</sup></b>	Alternate indicator location, other than std, 180° (i.e., I090 = 90°, I225 = 225°)
<b>DIN</b>	DIN Flanges (All Around)

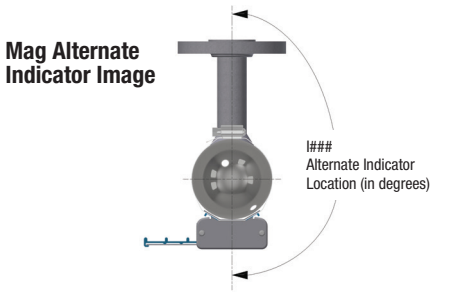

# MAGNicator® II Specification Guide – Model MII

## Chamber Style Illustrations



**CM**  
Welded Cap Top,  
Mating Flange Bottom

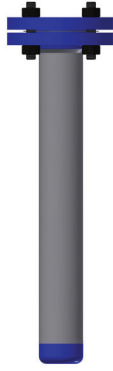

**MC**  
Mating Flange Top,  
Welded Cap Bottom



**MM**  
Mating Flange Top,  
Mating Flange Bottom

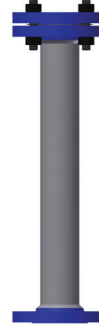

**MF**  
Mating Flange Top,  
Exposed Flange Bottom

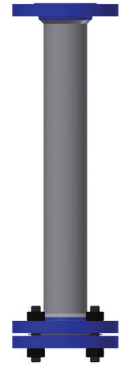

**FM**  
Exposed Flange Top,  
Mating Flange Bottom



**CF**  
Welded Cap Top,  
Exposed Flange Bottom

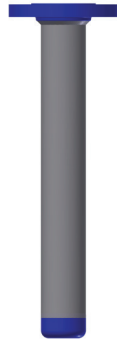

**FC**  
Exposed Flange Top,  
Welded Cap Bottom

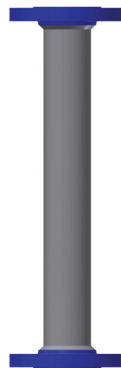

**FF**  
Exposed Flange Top,  
Exposed Flange Bottom



**CT**  
Welded Cap Top,  
Welded Cap with Thread  
(Chamber Access) Bottom



**TC**  
Welded Cap with Thread  
(Chamber Access) Top,  
Welded Cap Bottom



**TT**  
Welded Cap with Thread  
(Chamber Access) Top,  
Welded Cap with Thread  
(Chamber Access) Bottom

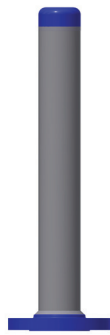

**B0**  
Top Mount (BEF)  
without Stilling Well  
or Guide Pipe



**B1**  
Top Mount (BEF)  
with Guide Pipe



**B2**  
Top Mount (BEF)  
with Stilling Well,  
Bottom End Open  
(Open to Tank Floor)



**B3**  
Top Mount (BEF)  
with Stilling Well,  
Bottom End Capped  
(Captured Float)



# MAGNicator® II Specification Guide

## *Model MGWRS*

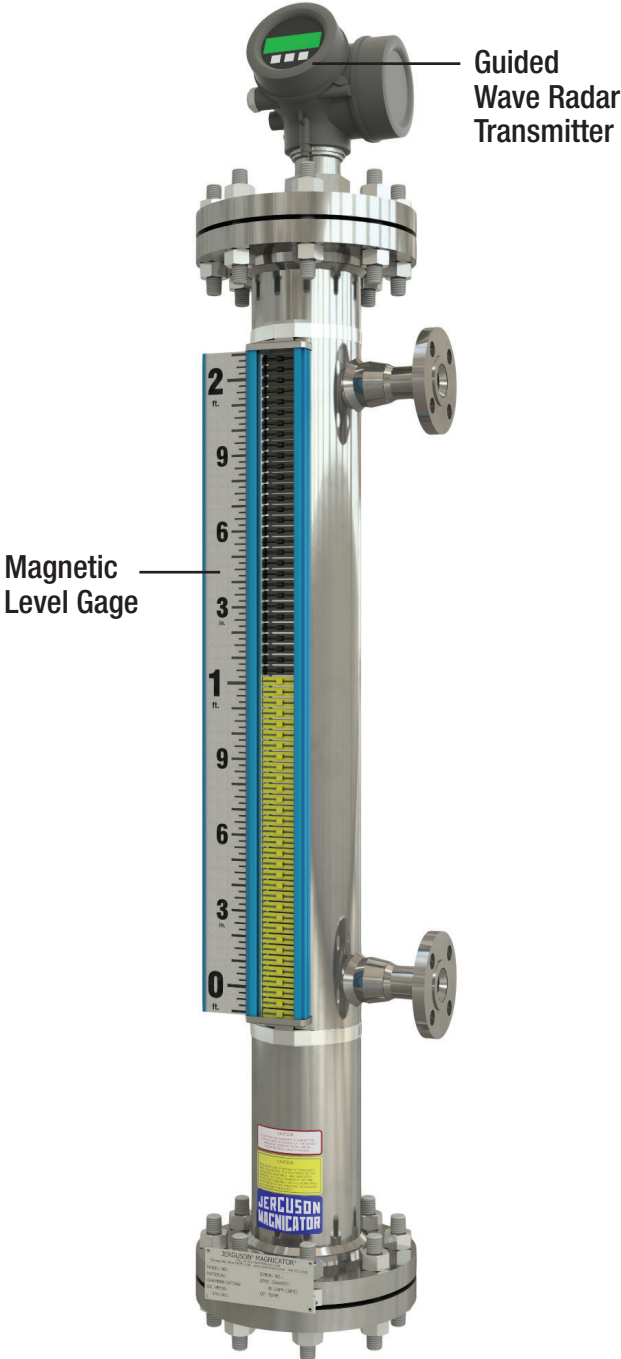

Model code requires Factory confirmation. Additional considerations (float OD, radar OD, etc.) beyond the model code scope, render some combinations invalid.

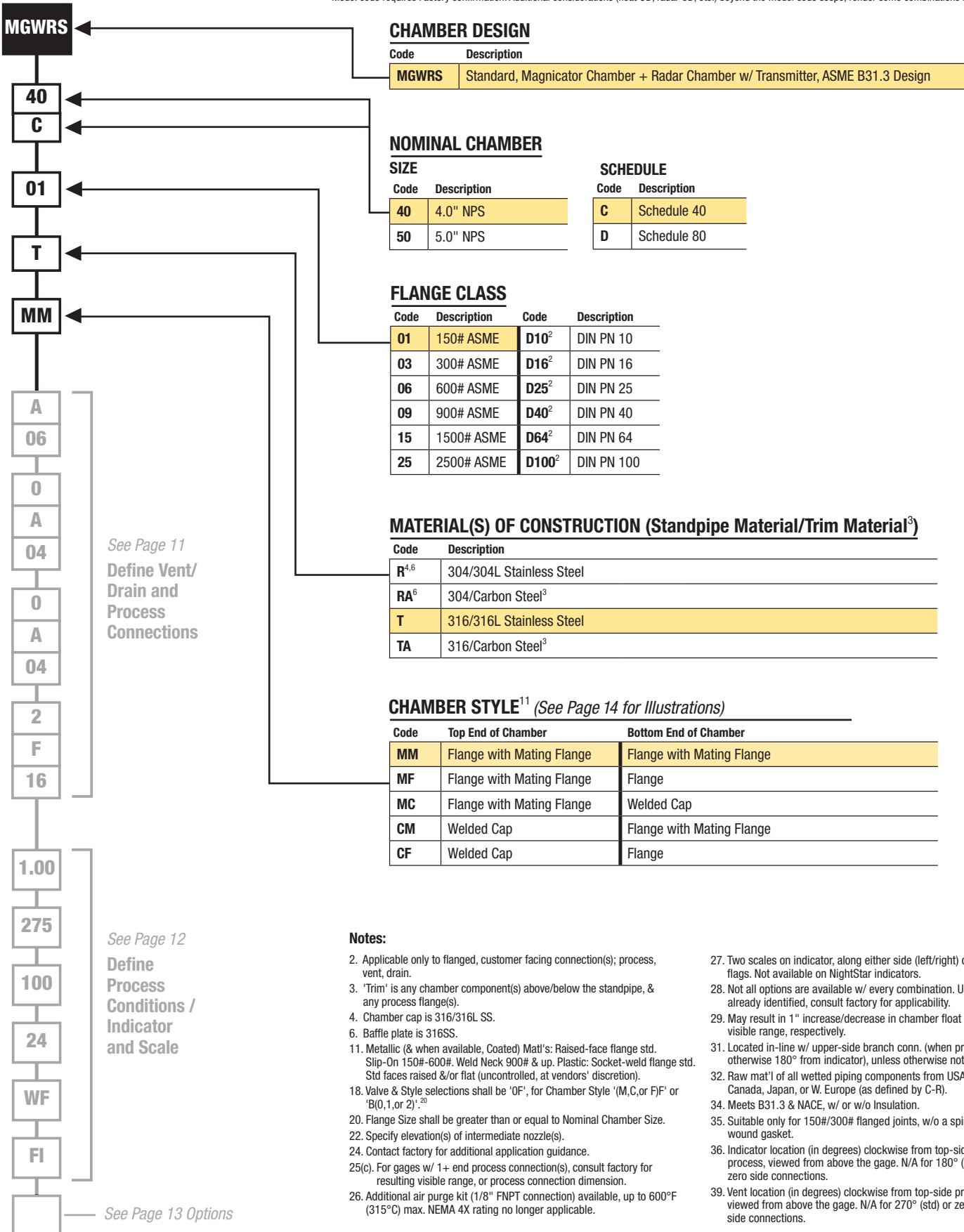

**Notes:**

2. Applicable only to flanged, customer facing connection(s); process, vent, drain.
3. 'Trim' is any chamber component(s) above/below the standpipe, & any process flange(s).
4. Chamber cap is 316/316L SS.
6. Baffle plate is 316SS.
11. Metallic (& when available, Coated) Mat's: Raised-face flange std. Slip-On 150#-600#. Weld Neck 900# & up. Plastic: Socket-weld flange std. Std faces raised &/or flat (uncontrolled, at vendors' discretion).
18. Valve & Style selections shall be 'OF', for Chamber Style '(M,C, or F)F' or 'B(0,1, or 2)'.<sup>20</sup>
20. Flange Size shall be greater than or equal to Nominal Chamber Size.
22. Specify elevation(s) of intermediate nozzle(s).
24. Contact factory for additional application guidance.
- 25(c). For gages w/ 1+ end process connection(s), consult factory for resulting visible range, or process connection dimension.
26. Additional air purge kit (1/8" FNPT connection) available, up to 600°F (315°C) max. NEMA 4X rating no longer applicable.
27. Two scales on indicator, along either side (left/right) of flags. Not available on NightStar indicators.
28. Not all options are available w/ every combination. Unless already identified, consult factory for applicability.
29. May result in 1" increase/decrease in chamber float leg/visible range, respectively.
31. Located in-line w/ upper-side branch conn. (when present, otherwise 180° from indicator), unless otherwise noted.
32. Raw mat'l of all wetted piping components from USA, Canada, Japan, or W. Europe (as defined by C-R).
34. Meets B31.3 & NACE, w/ w/o insulation.
35. Suitable only for 150#/300# flanged joints, w/o a spiral wound gasket.
36. Indicator location (in degrees) clockwise from top-side process, viewed from above the gage. N/A for 180° (std) or zero side connections.
39. Vent location (in degrees) clockwise from top-side process, viewed from above the gage. N/A for 270° (std) or zero side connections.

# MAGNicator® II Specification Guide – Model MGWRS

## Define Vent/Drain & Process Connections

Model code requires Factory confirmation. Additional considerations (float OD, radar OD, etc.) beyond the model code scope, render some combinations invalid.

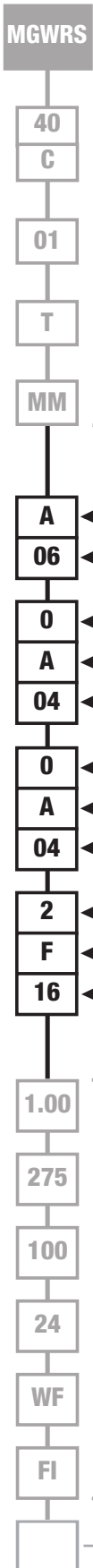

See Page 10  
Define Chamber & Materials

See Page 12  
Define Process Conditions / Indicator and Scale

See Page 13 Options

### RADAR CONNECTION

#### STYLE

Code	Description
A	FNPT (Female NPT)
F <sup>11</sup>	Flange

#### SIZE

Code	Description	Valid w/ Connection Style
06	3/4" (DN 20)	A
08	1" (DN 25)	A
12	1-1/2" (DN 40)	A, F
16	2" (DN 50)	F

### VENT CONNECTION - TOP-SIDE, STD. (See Page 26 for Illustrations)

#### VALVE

Code	Description
0	None
1	Gate
2	Globe
S	Spl/Custom Specified

#### STYLE

Code	Description
A	FNPT (Female NPT)
B	FSW (Female Socket Weld)
C	MNPT (Male NPT)
D	MSW (Male Socket Weld)
F <sup>11</sup>	Flange
K	None

#### SIZE

Code	Description	Valid w/ Connection Style
04	1/2" (DN 15)	A, B, C, D, F
06	3/4" (DN 20)	A, B, C, D, F
08	1" (DN 25)	A, B, C, D, F
12	1-1/2" (DN 40)	A, B, C, D, F
16	2" (DN 50)	F
00	N/A	K

### DRAIN/BOTTOM CHAMBER CONNECTION<sup>18</sup> (See Page 26 for Illustrations)

#### VALVE

Code	Description
0	None
1	Gate
2	Globe
S	Spl/Custom Specified

#### STYLE

Code	Description
A	FNPT (Female NPT)
B	FSW (Female Socket Weld)
C	MNPT (Male NPT)
D	MSW (Male Socket Weld)
F <sup>11</sup>	Flange
K	None

#### SIZE

Code	Description	Valid w/ Connection Style
04	1/2" (DN 15)	A, B, C, D, F
06	3/4" (DN 20)	A, B, C, D, F
08	1" (DN 25)	A, B, C, D, F
12	1-1/2" (DN 40)	A, B, C, D, F
16	2" (DN 50)	F
24	3" (DN 80)	F
32	4" (DN 100)	F
40	5" (DN 125)	F
00	N/A	K

### SIDE PROCESS CONNECTION(S)

#### NO. OF SIDE CONNECTIONS

Code	Description
1T	1 @ Top Side Only
2	2 Side Connections
# <sup>22</sup>	3+ Side Connections ('#', Specify Qty)

#### STYLE

Code	Description
A	FNPT (Female NPT)
B	FSW (Female Socket Weld)
C	MNPT (Male NPT)
D	MSW (Male Socket Weld)
F <sup>11</sup>	Flange
K	None

#### SIZE

Code	Description
04	1/2" (DN 15)
06	3/4" (DN 20)
08	1" (DN 25)
12	1-1/2" (DN 40)
16	2" (DN 50)
24	3" (DN 80)

# MAGNicator® II Specification Guide – Model MGWRS

## Define Process Conditions/Indicator & Scale

Model code requires Factory confirmation. Additional considerations (float OD, radar OD, etc.) beyond the model code scope, render some combinations invalid.

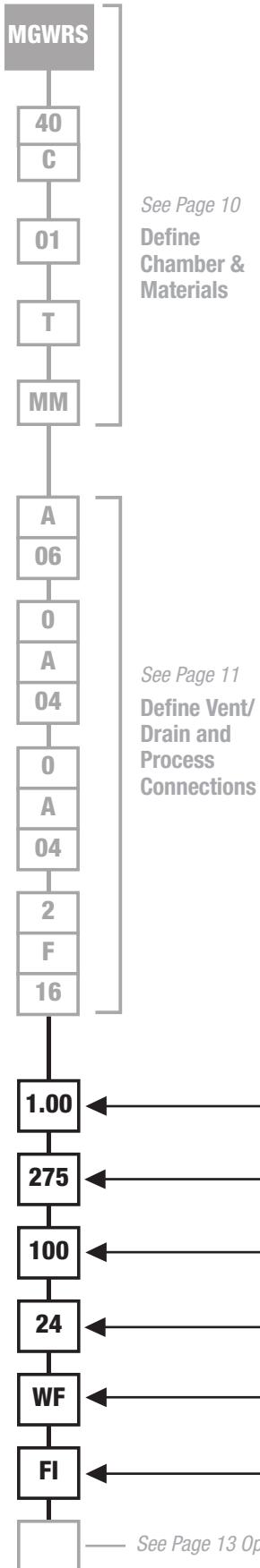

**SPECIFIC GRAVITY** 0.30 & Up, Depending on Float Style & Max Operating Conditions. For varying SG applications, specify min SG in the range. For interface applications,<sup>24</sup> specify "Upper Fluid"/"Lower Fluid" (0.1 Min Differential Req'd).

**MAXIMUM OPERATING PRESSURE (PSIG)** Up to 3500 psig (241 bar); Consult factory for greater values.

**MAXIMUM OPERATING TEMPERATURE (°F)** Up to 1000°F (537°C) max.

**VISIBLE RANGE / CENTER-CENTER or CENTER-FACE<sup>25</sup>**

Enter (1) value if visible range & center-to-center are equal. Exact inches (for mm, add "mm").

**FLAG STYLE INDICATOR**

Yellow (Liquid)/Black (Vapor) Colors Standard. See Options for Red/White Order Code. Consult Factory for Other Color Options.

Code	Description
WF	Wide Indicator (1-1/2" Flag), Sealed (NEMA 4X) in Anodized Aluminum Housing, 1000°F (537°C) Max
HWFP	Wide Indicator (1-1/2" Flag), Hermetically Sealed (IP68) in Polycarbonate Tube, Stainless Steel Frame, 500°F (260°C) Max
FL	Conventional Indicator (3/4" Flag), Sealed (NEMA 4X) in Anodized Aluminum Housing, 1000°F (537°C) Max
HFLP	Conventional Indicator (3/4" Flag), Hermetically Sealed (IP68) in Polycarbonate Tube, Stainless Steel Frame, 500°F (260°C) Max
HFLG	Conventional Indicator (3/4" Flag), Hermetically Sealed (IP68) in Glass Tube, Stainless Steel Frame, 1000°F (537°C) Max (Sealed Glass Tube Sections Stacked End to End w/ ~1.5" (38mm) Gap, when Visible Exceeds 78" (1981mm))
N### <sup>26</sup>	NightStar™ (USA/CAN) Illuminated Conventional Indicator (3/4" Flag), Sealed (NEMA 4X) in Anodized Aluminum Housing, 450°F (232°C) Max ('###' = Supply Power, VAC (i.e., N120 or N240))
N### <sup>26</sup>	NightStar™ (ATEX/IECEx) Illuminated Conventional Indicator (3/4" Flag), Sealed (NEMA 4X) in Anodized Aluminum Housing, 450°F (232°C) Max ('###' = Supply Power, VAC (i.e., NX120 or NX240))
NI	No Indicator

**SCALE TYPE**

Code	Description
FI	Feet/Inches
MM	Meter/Millimeter
PS	Percent Scale
SS	Special Scale
NS	No Scale
_/ _	Dual Scale <sup>27</sup> Format, Specify Types (Example: FI/MM)

Model code requires Factory confirmation. Additional considerations (float OD, radar OD, etc.) beyond the model code scope, render some combinations invalid.

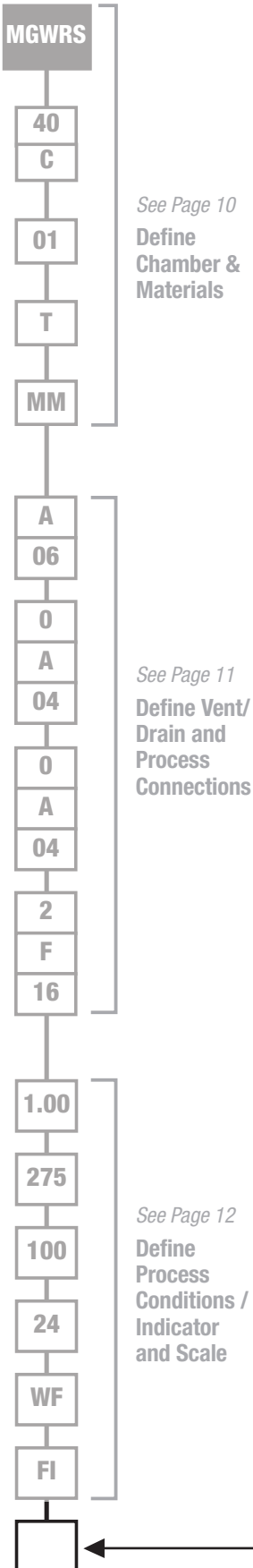

**OPTIONS<sup>28</sup>** To define multiple options, add additional codes as suffixes to model string.

Code	Description
<b>RW</b>	Red (Liquid) /White (Vapor) Flag Indicator Colors (Std is Yellow/Black)
<b>SF<sup>29</sup></b>	Sunken Float Indicator (1" Below Measuring Range, w/ Alternate Flag Color Indication)
<b>DI<sup>24</sup></b>	Dual Indication, Total Level & Interface (WF Series or Hermetic Indicators Only. Both SG's Req'd.)
<b>SW<sup>30</sup></b>	Socket-Weld Flanges (All Around, Up To & Including 600#, Consult Factory above 600#)
<b>WN</b>	Weld Neck Flanges (All Around, Up to & Including 600#. Std. above 600#)
<b>BR#<sup>31</sup></b>	Support Bracket(s) (# = No. of Brackets. Unless Otherwise Noted, Evenly Spaced Between Process Connections)
<b>NF</b>	Non-Frost Extension, 3-5/8" (92mm) Depth (Min. Temp. -300°F (-184°C))
<b>ST</b>	Steam Tracing, 3/8" (9.5mm) OD Tube with Compression Fitting
<b>E11</b>	Self-Regulating, 120VAC Electric Heat Trace, Cl.I, D1, Grps B,C,D. Consult Factory for Optional Thermostat.
<b>E12</b>	Self-Regulating, 120VAC Electric Heat Trace, Cl.I, D2, Grps B,C,D, NEMA 4X Enclosure. Consult Factory for optional thermostat.
<b>HI</b>	High Temperature Insulation, Flexible Jacket, 500°F (260°C)
<b>HI8</b>	High Temperature Insulation, Flexible Jacket, 800°F (426°C)
<b>NC</b>	NACE Compliant to MR0103/0175
<b>RMW<sup>32</sup></b>	Regionally Restricted Material
<b>B1</b>	Designed to ASME B31.1
<b>GR</b>	Flexible Graphite Gasket w/ 316 Stainless Steel Insert
<b>SWG</b>	Spiral Wound Gasket (Graphite Filler w/ Inner Ring & Windings To Match Chamber) (Std w/ 600# Class Flanges & Above)
<b>MT</b>	Magnetic Trap, In-Line w/ Bottom-Side Process Connection
<b>SE<sup>30</sup></b>	Stub End w/ Lap Joint (aka: 2-Piece) Process Flange (Up To & Including 600#)
<b>SP#</b>	Set Point Arrow(s) (# = No. of Arrows, Evenly Spaced Along Indicator, unless otherwise noted)
<b>SML</b>	Seamless Pipe
<b>S8</b>	Schedule 80 Nipples/Fittings (Does not apply to 1) Chamber, 2) Flange Class 600# & up (Std)
<b>S16</b>	Schedule 160 Nipples/Fittings (Does not apply to Chamber)
<b>B7M<sup>34</sup></b>	Cr-Mo Bolting (ASME A193 Gr.B7M Studs & ASME A194 Gr.2HM Nuts)
<b>B8M<sup>35</sup></b>	316SS Bolting (ASME A193 Gr.B8M, Class 1 Studs & ASME A194 Gr.8MA Nuts)
<b>I###<sup>36</sup></b>	Alternate indicator location, other than std, 180° (i.e., I090 = 90°, I225 = 225°)
<b>DIN</b>	DIN Flanges (All Around)
<b>V###<sup>39</sup></b>	Alternate vent location, other than std, 270°. [IE: I090 = 90°, I225 = 225°]
<b>UB##</b>	Upper Blocking distance (in whole inches), when other than std, 8". [IE: UB09 = 9", UB18 = 18"]

**MGWRS Alternate Indicator and Vent Image**

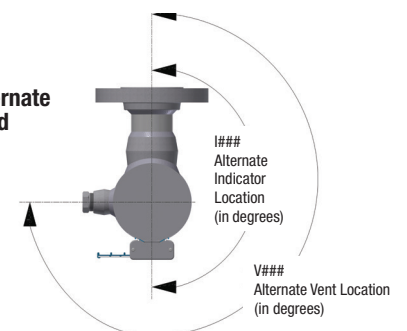



# MAGNicator® II Specification Guide – Model MGWRS

## Chamber Style Illustrations

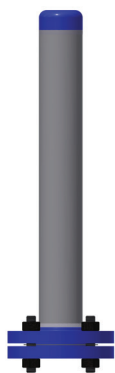

**CM**  
Welded Cap Top,  
Mating Flange Bottom



**MC**  
Mating Flange Top,  
Welded Cap Bottom

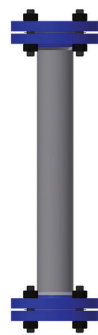

**MM**  
Mating Flange Top,  
Mating Flange Bottom

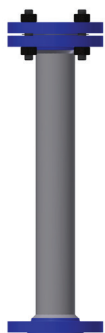

**MF**  
Mating Flange Top,  
Exposed Flange Bottom

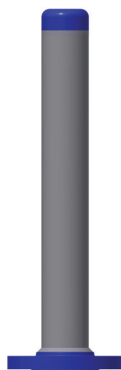

**CF**  
Welded Cap Top,  
Exposed Flange Bottom

# MAGNicator® II Specification Guide

## *Model MGWRD*

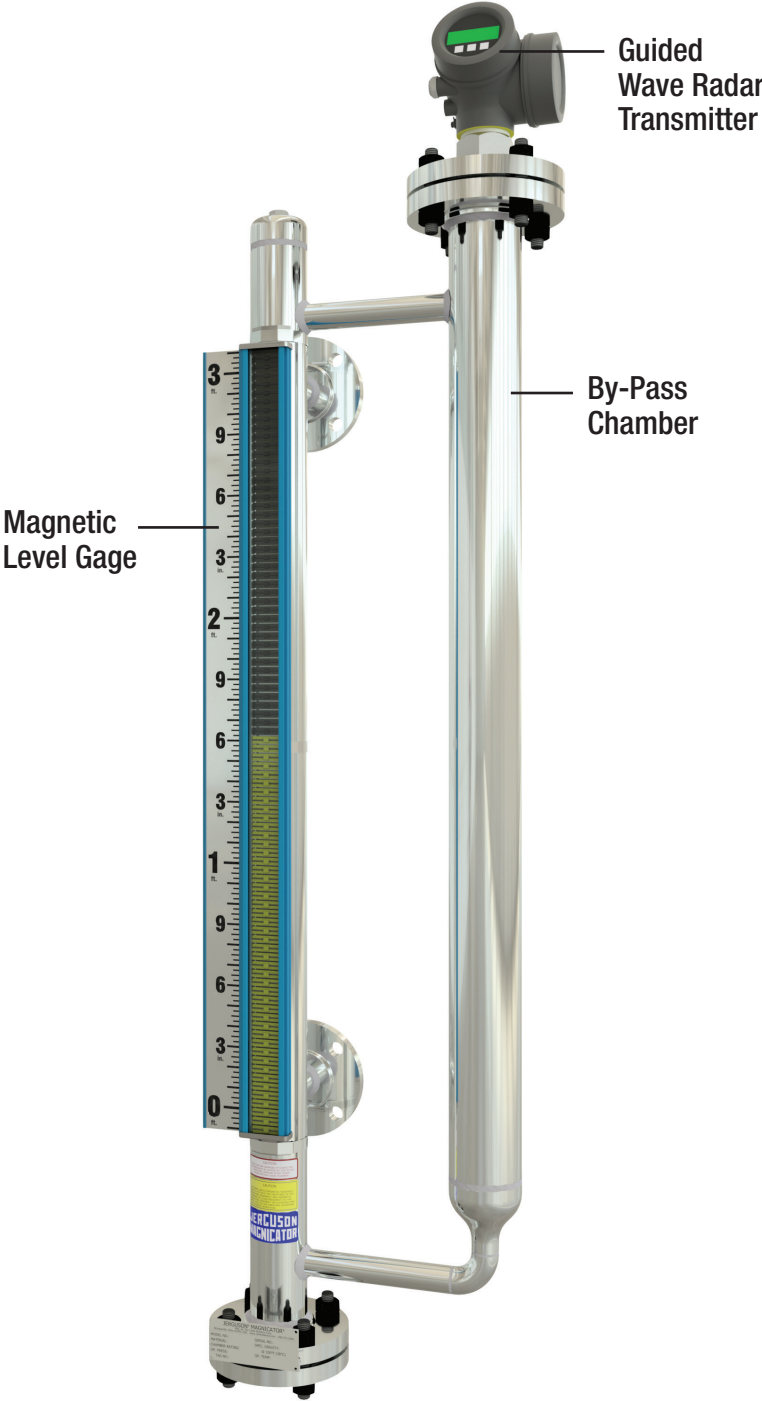

# Define Chamber & Materials

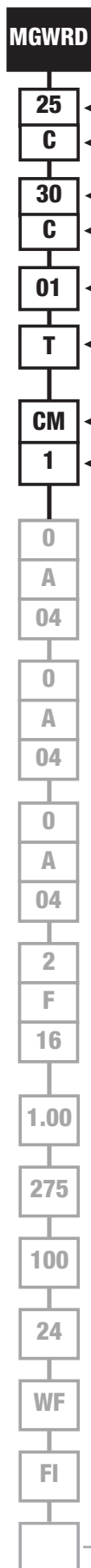

See Page 17  
Define Vent/  
Drain and  
Process  
Connections

See Page 18  
Define  
Process  
Conditions /  
Indicator  
and Scale

See Page 19 Options

## CHAMBER DESIGN

Code	Description
MGWRD	Standard, Magnicator Chamber + Radar Chamber w/ Transmitter, ASME B31.3 Design
MGWRDF	Flashproof Magnicator Chamber + Radar Chamber w/ Transmitter, ASME B31.3 Design

## NOMINAL MAGNicator CHAMBER

SIZE			
Code	Description	Valid w/Chamber Design	
20	2.0" NPS	MGWRD	
25	2.5" NPS	MGWRD	
30	3.0" NPS	MGWRD	MGWRDF

SCHEDULE			
Code	Description	Valid w/ Chamber Design/Size	
C	Sched. 40	MGWRD-20, 25, or 30	MGWRDF-30
D	Sched. 80	MGWRD-25 or 30	MGWRDF-30
E	Sched. 160	MGWRD-30	

## NOMINAL RADAR CHAMBER

SIZE		SCHEDULE	
Code	Description	Code	Description
20	2.0" NPS	C	Schedule 40
30	3.0" NPS	D	Schedule 80
40	4.0" NPS	E	Schedule 160

FLANGE CLASS			
Code	Description	Code	Description
01	150# ASME	D10 <sup>2</sup>	DIN PN 10
03	300# ASME	D16 <sup>2</sup>	DIN PN 16
06	600# ASME	D25 <sup>2</sup>	DIN PN 25
09	900# ASME	D40 <sup>2</sup>	DIN PN 40
15	1500# ASME	D64 <sup>2</sup>	DIN PN 64
25	2500# ASME	D100 <sup>2</sup>	DIN PN 100

## MATERIAL(S) OF CONSTRUCTION (Standpipe Material/Trim Material<sup>3</sup>)

Code	Description	Code	Description
R <sup>4,5</sup>	304/304L Stainless Steel	V <sup>7</sup>	317 Stainless Steel
RA <sup>5</sup>	304/Carbon Steel <sup>3</sup>	TT <sup>7</sup>	Titanium
T	316/316L Stainless Steel	LB3 <sup>7</sup>	Hastelloy® B3
TA	316/Carbon Steel <sup>3</sup>	MD4 <sup>7</sup>	Inconel® 600
K <sup>7</sup>	Alloy 20	MD13 <sup>7</sup>	Incoloy® 800
LC <sup>7</sup>	Hastelloy® C276	MD14 <sup>7</sup>	Inconel® 625
N <sup>7</sup>	Monel® 400	MD15 <sup>7</sup>	Incoloy® 825
S <sup>7</sup>	347 Stainless Steel	XL4 <sup>7</sup>	SMO 254, UNS 31254
Y <sup>7</sup>	321 Stainless Steel	ZZ <sup>7</sup>	Zirconium ZR2

## CHAMBER STYLES<sup>11</sup> (See Page 20 for Illustrations)

### MAGNicator CHAMBER STYLE

Code	Top End of Chamber	Bottom End of Chamber
CM	Welded Cap	Flange with Mating Flange
MC	Flange with Mating Flange	Welded Cap
MM	Flange with Mating Flange	Flange with Mating Flange
MF	Flange with Mating Flange	Flange
FM	Flange	Flange with Mating Flange
CF	Welded Cap	Flange
FC	Flange	Welded Cap
FF	Flange	Flange

### RADAR CHAMBER STYLE

Code	Top End of Chamber	Bottom End of Chamber
0	Capped, 1.50" NPT	Integral Elbow / Drain <sup>14</sup>
1	Flange	Integral Elbow / Drain <sup>14</sup>
2	Flange	Flange with Mating Flange

# Define Vent/Drain & Process Connections

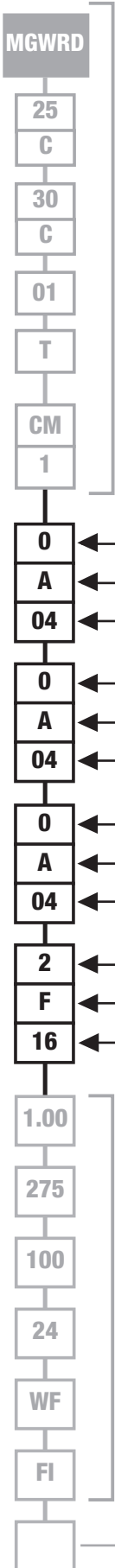

See Page 16  
Define Chambers & Materials

See Page 18  
Define Process Conditions / Indicator and Scale

See Page 19 Options

## VENT/TOP MAGNETIC CHAMBER CONNECTION<sup>16</sup> (See Page 26 for Illustrations)

VALVE		STYLE		SIZE		
Code	Description	Code	Description	Code	Description	Valid w/ Connection Style
0	None	A	FNPT (Female NPT)	04	1/2" (DN 15)	A, B, C, D, F
1	Gate	B	FSW (Female Socket Weld)	06	3/4" (DN 20)	A, B, C, D, F
2	Globe	C	MNPT (Male NPT)	08	1" (DN 25)	A, B, C, D, F
S	Spl/Custom Specified	D	MSW (Male Socket Weld)	12	1-1/2" (DN 40)	A, B, C, D, F
		F <sup>11</sup>	Flange	16	2" (DN 50)	F
		K	None	20	2-1/2" (DN 65)	F
				24	3" (DN 80)	F
				00	N/A	K

## DRAIN/BOTTOM MAGNETIC CHAMBER CONNECTION<sup>18</sup> (See Page 26 for Illustrations)

VALVE		STYLE		SIZE		
Code	Description	Code	Description	Code	Description	Valid w/ Connection Style
0	None	A	FNPT (Female NPT)	04	1/2" (DN 15)	A, B, C, D, F
1	Gate	B	FSW (Female Socket Weld)	06	3/4" (DN 20)	A, B, C, D, F
2	Globe	C	MNPT (Male NPT)	08	1" (DN 25)	A, B, C, D, F
S	Spl/Custom Specified	D	MSW (Male Socket Weld)	12	1-1/2" (DN 40)	A, B, C, D, F
		F <sup>11</sup>	Flange	16	2" (DN 50)	F
		K	None	24	3" (DN 80)	F
				00	N/A	K

## RADAR CHAMBER DRAIN<sup>23</sup> (See Page 26 for Illustrations)

VALVE		STYLE		SIZE		
Code	Description	Code	Description	Code	Description	Valid w/ Connection Style
0	None	A	FNPT (Female NPT)	04	1/2" (DN 15)	A, B, C, D, F
1	Gate	B	FSW (Female Socket Weld)	06	3/4" (DN 20)	A, B, C, D, F
2	Globe	C	MNPT (Male NPT)	08	1" (DN 25)	A, B, C, D, F
S	Spl/Custom Specified	D	MSW (Male Socket Weld)	12	1-1/2" (DN 40)	A, B, C, D, F
		F <sup>11</sup>	Flange	16	2" (DN 50)	F
		K	None	20	2-1/2" (DN 65)	F
				24	3" (DN 80)	F
				00	N/A	K

## SIDE PROCESS CONNECTION(S)

NO. OF SIDE CONNECTIONS		STYLE		SIZE	
Code	Description	Code	Description	Code	Description
0	No Side Connections	A	FNPT (Female NPT)	04	1/2" (DN 15)
1T	1 @ Top Side Only	B	FSW (Female Socket Weld)	06	3/4" (DN 20)
1B	1 @ Bottom Side Only	C	MNPT (Male NPT)	08	1" (DN 25)
2	2 Side Connections	D	MSW (Male Socket Weld)	12	1-1/2" (DN 40)
# <sup>22</sup>	3+ Side Connections ('#', Specify Qty)	F <sup>11</sup>	Flange	16	2" (DN 50)
		K	None	24	3" (DN 80)
				00	N/A

# Define Process Conditions/Indicator & Scale

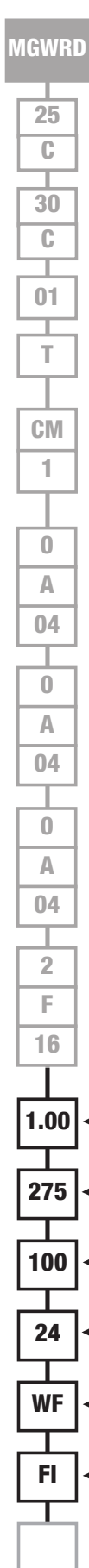

See Page 16  
Define Chambers & Materials

See Page 17  
Define Vent/ Drain and Process Connections

See Page 19 Options

**SPECIFIC GRAVITY** 0.30 & Up, Depending on Float Style & Max Operating Conditions. For varying SG applications, specify min SG in the range. For interface applications;<sup>24</sup> specify "Upper Fluid"/"Lower Fluid" (0.1 Min Differential Req'd).

**MAXIMUM OPERATING PRESSURE (PSIG)** Up to 3500 psig (241 bar); Consult factory for greater values.

**MAXIMUM OPERATING TEMPERATURE (°F)** Up to 1000°F (537°C) max.

**VISIBLE RANGE / CENTER-CENTER or FACE-FACE or CENTER-FACE**<sup>25</sup>  
Enter (1) value if visible range & center-to-center are equal. Exact inches (for mm, add "mm").

**FLAG STYLE INDICATOR** Yellow (Liquid)/Black (Vapor) Colors Standard. See Options for Red/White Order Code. Consult Factory for Other Color Options.

Code	Description
WF	Wide Indicator (1-1/2" Flag), Sealed (NEMA 4X) in Anodized Aluminum Housing, 1000°F (537°C) Max
HWFP	Wide Indicator (1-1/2" Flag), Hermetically Sealed (IP68) in Polycarbonate Tube, Stainless Steel Frame, 500°F (260°C) Max
FL	Conventional Indicator (3/4" Flag), Sealed (NEMA 4X) in Anodized Aluminum Housing, 1000°F (537°C) Max
HFLP	Conventional Indicator (3/4" Flag), Hermetically Sealed (IP68) in Polycarbonate Tube, Stainless Steel Frame, 500°F (260°C) Max
HFLG	Conventional Indicator (3/4" Flag), Hermetically Sealed (IP68) in Glass Tube, Stainless Steel Frame, 1000°F (537°C) Max (Sealed Glass Tube Sections Stacked End to End w/ ~1.5" (38mm) Gap, when Visible Exceeds 78" (1981mm))
N### <sup>26</sup>	NightStar™ (USA/CAN) Illuminated Conventional Indicator (3/4" Flag), Sealed (NEMA 4X) in Anodized Aluminum Housing, 450°F (232°C) Max ('###' = Supply Power, VAC (i.e., N120 or N240))
NX### <sup>26</sup>	NightStar™ (ATEX/IECEx) Illuminated Conventional Indicator (3/4" Flag), Sealed (NEMA 4X) in Anodized Aluminum Housing, 450°F (232°C) Max ('###' = Supply Power, VAC (i.e., NX120 or NX240))
NI	No Indicator

**SCALE TYPE**

Code	Description
FI	Feet/Inches
MM	Meter/Millimeter
PS	Percent Scale
SS	Special Scale
NS	No Scale
—/—	Dual Scale <sup>27</sup> Format, Specify Types (Example: FI/MM)

**Notes:**

- Applicable only to flanged, customer facing connection(s); process, vent, drain.
- 'Trim' is any chamber component(s) above/below the standpipe, & any process flange(s).
- Chamber cap is 316/316L SS.
- Guide bars (when flashproof) are 316/316L SS.
- Consult factory for chamber size code.
- Metallic (& when available, Coated) Materials: Raised-face flange std. Slip-On 150#-600#. Weld Neck 900# & up. Plastic: Socket-weld flange std. Std faces raised &/or flat (uncontrolled, at vendors' discretion).
- Integral elbow not considered 'TRIM' material.<sup>3</sup>
- Valve & Style selections shall be '0F', for Chamber Style 'F(M,C,or F)'.<sup>20</sup>
- Valve & Style selections shall be '0F', for Chamber Style '(M,C,or F)' or 'B(0,1,or 2)'.<sup>20</sup>
- Flange Size shall be greater than or equal to Nominal Chamber Size.

- Specify elevation(s) of intermediate nozzle(s).
- Radar Chamber Drain selection shall be '0K00', for Radar Chamber Styles 0 & 1.
- Contact factory for additional application guidance.
- A multiple section chamber may be required when range/center exceeds mat'l/application limits; ~225" metallic & CPVC, ~175" PVDF, ~100" coated. Each joint shall be flanged, have a break in the measuring range, include support/lifting brackets on either side. Consult factory for continuous chamber options.
- For gages w/ 1+ end process connection(s), consult factory for resulting visible range, or process connection dimension.
- Additional air purge kit (1/8" FNPT connection) available, up to 600°F (315°C) max. NEMA 4X rating no longer applicable.
- Two scales on indicator, along either side (left/right) of flags. Not available on NightStar indicators.
- Not all options are available w/ every combination. Unless already identified, consult factory for applicability.
- May result in 1" increase/decrease in chamber float leg/visible range, respectively.
- Located in-line w/ upper-side branch conn. (when present, otherwise 180° from indicator), unless otherwise noted.
- Raw mat'l of all wetted piping components from USA, Canada, Japan, or W. Europe (as defined by C-R)
- Meets B31.3 & NACE, w/ or w/o Insulation.
- Suitable only for 150#/300# flanged joints, w/o a spiral wound gasket.
- Indicator location (in degrees) clockwise from top-side process, viewed from above the gage. N/A for 180° (std) or zero side connections.
- Radar chamber location (in degrees) clockwise from top-side process, viewed from above the gage. N/A for 90° (std) or zero side connections.



# Define Options

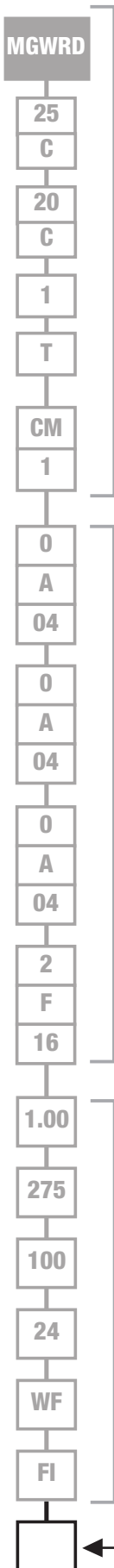

See Page 16  
Define Chambers & Materials

See Page 17  
Define Vent/ Drain and Process Connections

See Page 18  
Define Process Conditions / Indicator and Scale

**OPTIONS<sup>28</sup>** To define multiple options, add additional codes as suffixes to model string.

Code	Description
<b>RW</b>	Red (Liquid) /White (Vapor) Flag Indicator Colors (Std is Yellow/Black)
<b>SF<sup>29</sup></b>	Sunken Float Indicator (1" Below Measuring Range, w/ Alternate Flag Color Indication)
<b>DI<sup>24</sup></b>	Dual Indication, Total Level & Interface (WF Series or Hermetic Indicators Only. Both SG's Req'd.)
<b>SW</b>	Socket-Weld Flanges (All Around, Up To & Including 600#, Consult Factory above 600#)
<b>WN</b>	Weld Neck Flanges (All Around, Up to & Including 600#. Std. above 600#)
<b>BW</b>	Butt Weld Construction (Includes Full Bore Butt Weld Tees @ Branch Connections, & WN Flanges)
<b>BR#<sup>31</sup></b>	Support Bracket(s) (# = No. of Brackets. Unless Otherwise Noted, Evenly Spaced Between Process Connections)
<b>NF</b>	Non-Frost Extension, 3-5/8" (92mm) Depth (Min. Temp. -300°F (-184°C))
<b>CI</b>	Cold Insulation, 2" (50mm) Nominal Rigid Foam w/ Alum Jacket, -297°F (-182°C) to 300°F (148°C). Non-Frost (NF) Ext Included.
<b>ST</b>	Steam Tracing, 3/8" (9.5mm) OD Tube with Compression Fitting
<b>E11</b>	Self-Regulating, 120VAC Electric Heat Trace, Cl.I, D1, Grps B,C,D. Consult Factory for Optional Thermostat.
<b>E12</b>	Self-Regulating, 120VAC Electric Heat Trace, Cl.I, D2, Grps B,C,D, NEMA 4X Enclosure. Consult Factory for Optional Thermostat.
<b>HI</b>	High Temperature Insulation, Flexible Jacket, 500°F (260°C)
<b>HI8</b>	High Temperature Insulation, Flexible Jacket, 800°F (426°C)
<b>NC</b>	NACE Compliant to MR0103/0175
<b>RMW<sup>32</sup></b>	Regionally Restricted Material
<b>B1</b>	Designed to ASME B31.1
<b>GR</b>	Flexible Graphite Gasket w/ 316 Stainless Steel Insert
<b>SWG</b>	Spiral Wound Gasket (Graphite Filler w/ Inner Ring & Windings To Match Chamber)
	(Std w/ 600# Class Flanges & Above)
<b>MT</b>	Magnetic Trap, In-Line w/ Bottom-Side Process Connection
<b>SE</b>	Stub End w/ Lap Joint (aka: 2-Piece) Process Flange (Up To & Including 600#)
<b>SP#</b>	Set Point Arrow(s) (# = No. of Arrows, Evenly Spaced Along Indicator, unless otherwise noted)
<b>SML</b>	Seamless Pipe
<b>S8</b>	Schedule 80 Nipples/Fittings (Does not apply to 1) Chamber, 2) Flange Class 600# & up (Std))
<b>S16</b>	Schedule 160 Nipples/Fittings (Does not apply to Chamber)
<b>B7M<sup>34</sup></b>	Cr-Mo Bolting (ASME A193 Gr.B7M Studs & ASME A194 Gr.2HM Nuts)
<b>B8M<sup>35</sup></b>	316SS Bolting (ASME A193 Gr.B8M, Class 1 Studs & ASME A194 Gr.8MA Nuts)
<b>I###<sup>36</sup></b>	Alternate indicator location, other than std, 180° (i.e., I090 = 90°, I225 = 225°)
<b>R###<sup>37</sup></b>	Alternate radar chamber location, other than std, 90°. [IE: R180 = 180°, R270 = 270°]
<b>DIN</b>	DIN Flanges (All Around)
<b>UB##</b>	Upper Blocking distance (in whole inches), when other than std, 8". [IE: UB09 = 9", UB18 = 18"]

**MGWRD Configuration Dimensions**

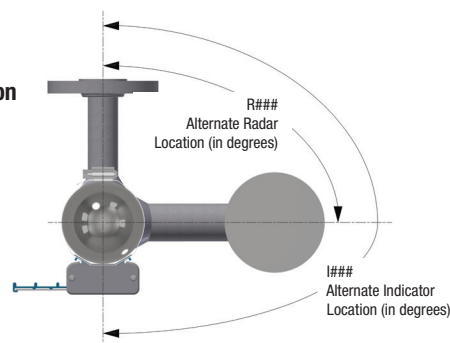

# MAGNicator® II Specification Guide – Model MGWRD

## Chamber Style Illustrations



**CM0**  
Cap Top/Mated Flg Bottom,  
Cap/Elbow

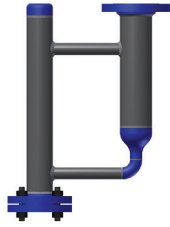

**CM1**  
Cap Top/Mated Flg Bottom,  
Flg/Elbow

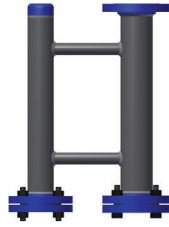

**CM2**  
Cap Top/Mated Flg Bottom,  
Flg/Mating Flg



**MC0**  
Mated Flg Top/Cap Bottom,  
Cap/Elbow



**MC1**  
Mated Flg Top/Cap Bottom,  
Flg/Elbow



**MC2**  
Mated Flg Top/Cap Bottom,  
Flg/Mating Flg



**MM0**  
Mated Flg Top/Mated Flg Bot,  
Cap/Elbow



**MM1**  
Mated Flg Top/Mated Flg Bot,  
Flg/Elbow



**MM2**  
Mated Flg Top/Mated Flg Bot,  
Flg/Mating Flg



**MF0**  
Mated Flg Top/Flange Bot,  
Cap/Elbow



**MF1**  
Mated Flg Top/Flange Bot,  
Flg/Elbow



**MF2**  
Mated Flg Top/Flange Bot,  
Flg/Mating Flg



**FM0**  
Flange Top/Mated Flg Bot,  
Cap/Elbow



**FM1**  
Flange Top/Mated Flg Bot,  
Flg/Elbow



**FM2**  
Flange Top/Mated Flg Bot,  
Flg/Mating Flg



**CF0**  
Cap Top/Mated Flg Bot,  
Cap/Elbow



**CF1**  
Cap Top/Flange Bot,  
Flg/Elbow

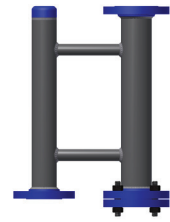

**CF2**  
Cap Top/Flange Bot,  
Flg/Mating Flg



**FC0**  
Flange Top/Cap Bot,  
Cap/Elbow



**FC1**  
Flange Top/Cap Bot,  
Flg/Elbow



**FC2**  
Flange Top/Cap Bot,  
Flg/Mating Flg



**FF0**  
Flange Top/Flange Bot,  
Flg/Mating Flg



**FF1**  
Flange Top/Flange Bot,  
Flg/Mating Flg



**FF2**  
Flange Top/Flange Bot,  
Flg/Mating Flg

# MAGNicator® II Specification Guide

## *Model BPC*



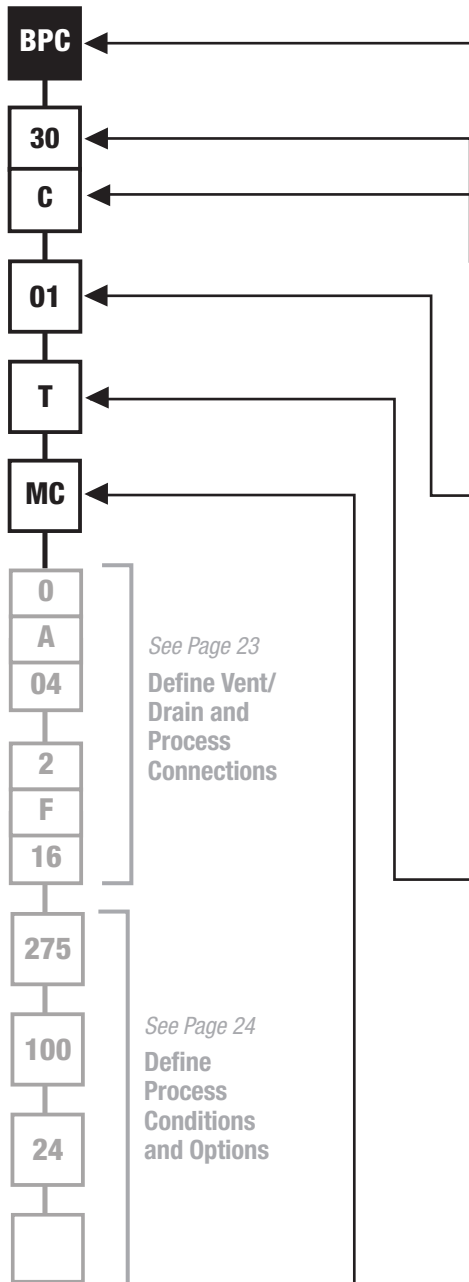

### CHAMBER DESIGN

Code	Description
<b>BPC</b>	Bypass Chamber w/ Top-Mount Radar Transmitter, ASME B31.3 Design

### NOMINAL CHAMBER

SIZE		SCHEDULE	
Code	Description	Code	Description
20	2.0" NPS	<b>C</b>	Schedule 40
<b>30</b>	3.0" NPS	D	Schedule 80
40	4.0" NPS	E	Schedule 160

### FLANGE CLASS

Code	Description	Code	Description
00	N/A, No Flanges	<b>D10<sup>2</sup></b>	DIN PN 10
<b>01</b>	150# ASME	<b>D16<sup>2</sup></b>	DIN PN 16
03	300# ASME	<b>D25<sup>2</sup></b>	DIN PN 25
06	600# ASME	<b>D40<sup>2</sup></b>	DIN PN 40
09	900# ASME	<b>D64<sup>2</sup></b>	DIN PN 64
15	1500# ASME	<b>D100<sup>2</sup></b>	DIN PN 100
25	2500# ASME		

### MATERIAL OF CONSTRUCTION

Code	Description	Code	Description
<b>R<sup>4</sup></b>	304/304L Stainless Steel	<b>TT<sup>7</sup></b>	Titanium
<b>T</b>	316/316L Stainless Steel	<b>LB3<sup>7</sup></b>	Hastelloy® B3
A	Carbon Steel	<b>MD4<sup>7</sup></b>	Inconel® 600
<b>K<sup>7</sup></b>	Alloy 20	<b>MD13<sup>7</sup></b>	Incoloy® 800
<b>LC<sup>7</sup></b>	Hastelloy® C276	<b>MD14<sup>7</sup></b>	Inconel® 625
<b>N<sup>7</sup></b>	Monel® 400	<b>MD15<sup>7</sup></b>	Incoloy® 825
<b>S<sup>7</sup></b>	347 Stainless Steel	<b>XL4<sup>7</sup></b>	SMO 254, UNS 31254
<b>Y<sup>7</sup></b>	321 Stainless Steel	<b>ZZ<sup>7</sup></b>	Zirconium ZR2
<b>V<sup>7</sup></b>	317 Stainless Steel		

### CHAMBER STYLE<sup>11, 15</sup> (See Page 25 for Illustrations)

Code	Top End of Chamber	Bottom End of Chamber
<b>MC</b>	Flange with Mating Flange	Welded Cap
<b>MM</b>	Flange with Mating Flange	Flange with Mating Flange
<b>MF</b>	Flange with Mating Flange	Flange
<b>CC</b>	Welded Cap	Welded Cap
<b>CM</b>	Welded Cap	Flange with Mating Flange
<b>CF</b>	Welded Cap	Flange
<b>FC</b>	Flange (Chamber Only, Radar Not Supplied)	Welded Cap
<b>FM</b>	Flange (Chamber Only, Radar Not Supplied)	Flange with Mating Flange
<b>FF</b>	Flange (Chamber Only, Radar Not Supplied)	Flange

# Define Vent/Drain & Process Connections

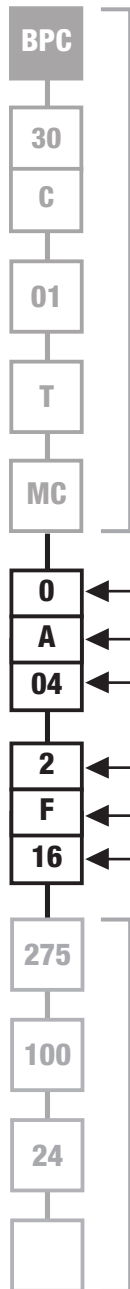

See Page 22  
Define Chamber & Materials

## DRAIN/BOTTOM CHAMBER CONNECTION<sup>18</sup> (See Page 26 for Illustrations)

VALVE		STYLE		SIZE		
Code	Description	Code	Description	Code	Description	Valid w/ Connection Style
0	None	A	FNPT (Female NPT)	04	1/2" (DN 15)	A, B, C, D, F
1	Gate	B	FSW (Female Socket Weld)	06	3/4" (DN 20)	A, B, C, D, F
2	Globe	C	MNPT (Male NPT)	08	1" (DN 25)	A, B, C, D, F
S	Spl/Custom Specified	D	MSW (Male Socket Weld)	12	1-1/2" (DN 40)	A, B, C, D, F
		F <sup>11</sup>	Flange	16	2" (DN 50)	F
		K	None	24	3" (DN 80)	F
				32	4" (DN 100)	F
				00	N/A	K

## SIDE PROCESS CONNECTION(S)

NO. OF SIDE CONNECTIONS		STYLE		SIZE	
Code	Description	Code	Description	Code	Description
0	No Side Connections	A	FNPT (Female NPT)	04	1/2" (DN 15)
1T	1 @ Top Side Only	B	FSW (Female Socket Weld)	06	3/4" (DN 20)
2	2 Side Connections	C	MNPT (Male NPT)	08	1" (DN 25)
# <sup>22</sup>	3+ Side Connections ('#', Specify Qty)	D	MSW (Male Socket Weld)	12	1-1/2" (DN 40)
		F <sup>11</sup>	Flange	16	2" (DN 50)
		K	None	24	3" (DN 80)
				00	N/A

See Page 24  
Define Process Conditions and Options

### Notes:

2. Applicable only to flanged, customer facing connection(s); process, vent, drain.
4. Chamber cap is 316/316L SS.
7. Consult factory for chamber size code.
11. Metallic (& when available, Coated) Materials: Raised-face flange std. Slip-On 150#-600#. Weld Neck 900# & up. Plastic: Socket-weld flange std. Std faces raised &/or flat (uncontrolled, at vendors' discretion).
15. Chamber Style shall be 'CC' for Flange Class selection '00'.
18. Valve & Style selections shall be '0F', for Chamber Style '(M,C, or FF)' or 'B(0,1, or 2)'.<sup>20</sup>
20. Flange Size shall be greater than or equal to Nominal Chamber Size.
22. Specify elevation(s) of intermediate nozzle(s).
- 25(a). A multiple section chamber may be required when range/center exceeds mat'l/application limits; ~225" metallic & CPVC, ~175" PVDF, ~100" coated. Each joint shall be flanged, have a break in the measuring range, include support/lifting brackets on either side. Consult factory for continuous chamber options.
- 25(c). For gages w/ 1+ end process connection(s), consult factory for resulting visible range, or process connection dimension.
28. Not all options are available w/ every combination. Unless already identified, consult factory for applicability.
31. Located in-line w/ upper-side branch conn. (when present, otherwise 180° from indicator), unless otherwise noted.
32. Raw material of all wetted piping components from USA, Canada, Japan, or W. Europe (as defined by C-R)
34. Meets B31.3 & NACE, w/ or w/o Insulation.
35. Suitable only for 150#/300# flanged joints, w/o a spiral wound gasket.
38. Chamber styles C\_ or M\_ only. Chamber style M\_ includes upper mating flange, hardware & gasket.



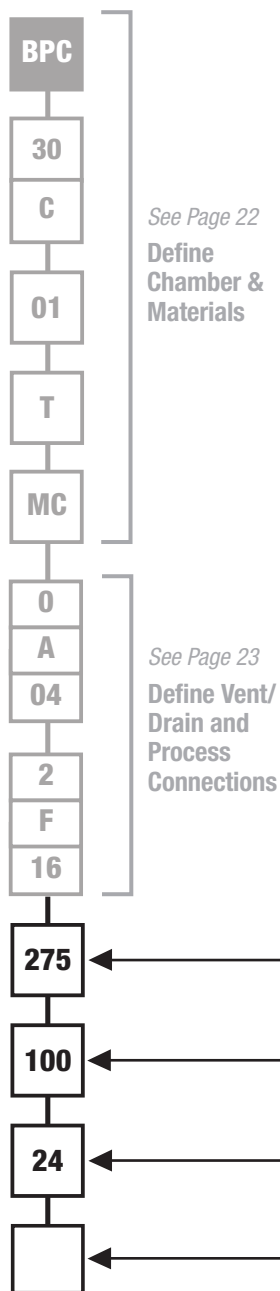

**MAXIMUM OPERATING PRESSURE (PSIG)** Up to 3500 psig (241 bar); Consult factory for greater values.

**MAXIMUM OPERATING TEMPERATURE (°F)** Up to 1000°F (537°C) max.

**MEASURING RANGE/CENTER-CENTER, FACE-FACE or CENTER-FACE<sup>25</sup>**

Enter (1) value if measuring range & center-to-center are equal. Exact inches (for mm, add "mm").

**OPTIONS<sup>28</sup>** To define multiple options, add additional codes as suffixes to model string.

Code	Description
SW	Socket-Weld Flanges (All Around, Up To & Including 600#, Consult Factory above 600#)
WN	Weld Neck Flanges (All Around, Up to & Including 600#. Std. above 600#)
BW	Butt Weld Construction (Includes Full Bore Butt Weld Tees @ Branch Connections, & WN Flanges)
FB	Full Bore Construction @ Branch Connection (When Allowed by Main Run-Branch Run Construction)
BR# <sup>31</sup>	Support Bracket(s) (# = No. of Brackets. Unless Otherwise Noted, Evenly Spaced Between Process Connections)
CI	Cold Insulation, 2" (50mm) Nominal Rigid Foam w/ Alum Jacket, -297°F (-182°C) to 300°F (148°C). Requires Non-Frost (NF) Extension.
ST	Steam Tracing, 3/8" (9.5mm) OD Tube with Compression Fitting
E11	Self-Regulating, 120VAC Electric Heat Trace, Cl.I, D1, Grps B,C,D. Consult Factory for Optional Thermostat.
E12	Self-Regulating, 120VAC Electric Heat Trace, Cl.I, D2, Grps B,C,D, NEMA 4X Enclosure. Consult Factory for Optional Thermostat.
HI	High Temperature Insulation, Flexible Jacket, 500°F (260°C)
HI8	High Temperature Insulation, Flexible Jacket, 800°F (426°C)
BC	Designed to ASME Section I Boiler Code, 900 PSIG Max. Oper. Press. (Refer to Boiler Code Bulletin)
NC	NACE Compliant to MR0103/0175
RMW <sup>32</sup>	Regionally Restricted Material
B1	Designed to ASME B31.1
GR	Flexible Graphite Gasket w/ 316 Stainless Steel Insert
SWG	Spiral Wound Gasket (Graphite Filler w/ Inner Ring & Windings To Match Chamber) (Std w/ 600# Class Flanges & Above)
SE	Stub End w/ Lap Joint (aka: 2-Piece) Process Flange (Up To & Including 600#)
SML	Seamless Pipe
S8	Schedule 80 Nipples/Fittings (Does not apply to 1) Chamber, 2) Flange Class 600# & up (Std))
S16	Schedule 160 Nipples/Fittings (Does not apply to Chamber)
B7M <sup>34</sup>	Cr-Mo Bolting (ASME A193 Gr.B7M Studs & ASME A194 Gr.2HM Nuts)
B8M <sup>35</sup>	316SS Bolting (ASME A193 Gr.B8M, Class 1 Studs & ASME A194 Gr.8MA Nuts)
DIN	DIN Flanges (All Around)
BL##	Bleed Ring, w/ Plugged Female NPT (Refer to 'Size' code from 'Drain/Bottom...Connection', for ##)
NR <sup>38</sup>	No Radar, not supplied. Vent Connection same as Drain Connection
UB##	Upper Blocking distance (in whole inches), when other than std, 8". [IE: UB09 = 9", UB18 = 18"]

# MAGNicator® II Specification Guide – Model BPC

## Chamber Style Illustrations

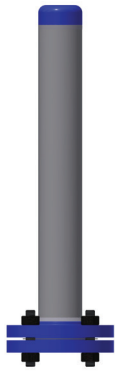

**CM**  
Welded Cap Top,  
Mating Flange Bottom

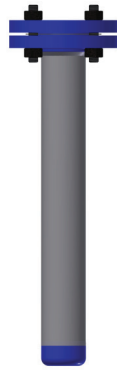

**MC**  
Mating Flange Top,  
Welded Cap Bottom



**MM**  
Mating Flange Top,  
Mating Flange Bottom



**MF**  
Mating Flange Top,  
Exposed Flange Bottom

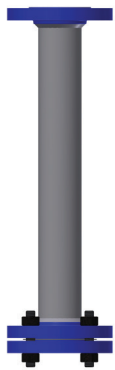

**FM**  
Exposed Flange Top,  
Mating Flange Bottom

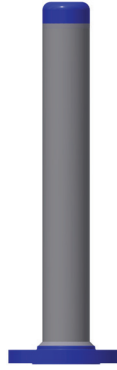

**CF**  
Welded Cap Top,  
Exposed Flange Bottom

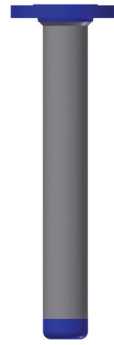

**FC**  
Exposed Flange Top,  
Welded Cap Bottom

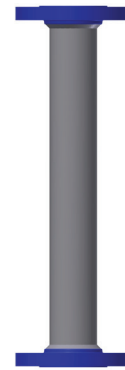

**FF**  
Exposed Flange Top,  
Exposed Flange Bottom

# Vent & Drain Styles



Cap FNPT

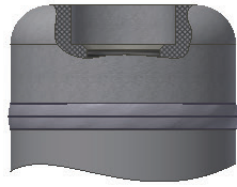

Cap FSW



Cap MNPT



Cap MSW



Cap Flanged



Cap Valve FNPT



Cap Valve FSW



Cap Valve MNPT



Cap Valve MSW



Cap Valve Flanged

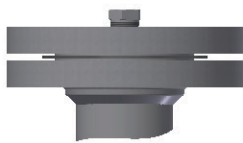

Flange FNPT

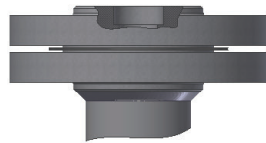

Flange FSW



Flange MNPT

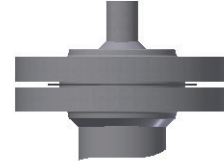

Flange MSW

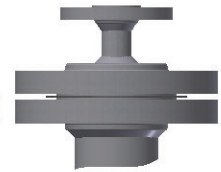

Flange Flanged



Flange Valve FNPT

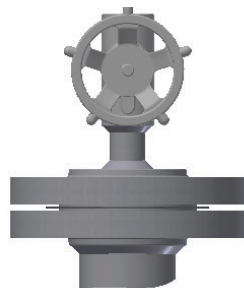

Flange Valve FSW

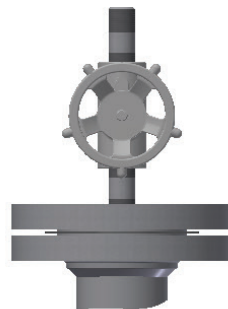

Flange Valve MNPT

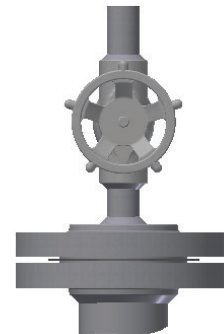

Flange Valve MSW



Flange Valve Flanged

# Discover a World of Solutions

## Explore Our Resources

### Online 3D Model Building Capability Now Available



- Create and download models
- Make custom drawings
- Generate data sheets for specific designs



### 48-Hour Magnicator Shipment Program



- Common options and accessories
- Includes indicator and floats for retrofit applications
- Easy configuration guide



### Clark-Reliance

strives to educate our employees, sales channel, and customers on products, solutions, and industry trends. Visit [Jerguson.com](http://Jerguson.com), youtube or LinkedIn for the latest Webinars, Videos, Tech Papers & Case Studies.



JERGUSON.COM

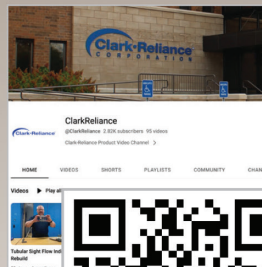

YOUTUBE



LINKEDIN

# MORE **Jerguson**<sup>®</sup> SOLUTIONS



**Jerguson**<sup>®</sup>  
360<sup>™</sup> Valve



**Jerguson**<sup>®</sup> Tri-Magnet<sup>™</sup>  
Level Switches



**Jerguson**<sup>®</sup> SafeView<sup>™</sup>  
Safety & Protection



**Jerguson**<sup>®</sup> LumaStar<sup>™</sup>  
Level Gage Illuminators



16633 Foltz Parkway, Strongsville, OH 44149 USA Phone: 440.572.1500 Fax: 440.238.8828  
www.clark-reliance.com sales@clark-reliance.com



ISO 9001:2000