

MATERIAL: SEE B/M
 DRAWN: TFK CHECKED: DEP
 SCALE: NONE DATE: 9/15/95



THREADED SIGHT WINDOW
 STYLE S-5400

Section: T400
 Bulletin: T400.59
 Date: 12/01/00
 Supersedes: 11/10/98

150 PSIG MODELS

FILE NO.: T400-59.DWG

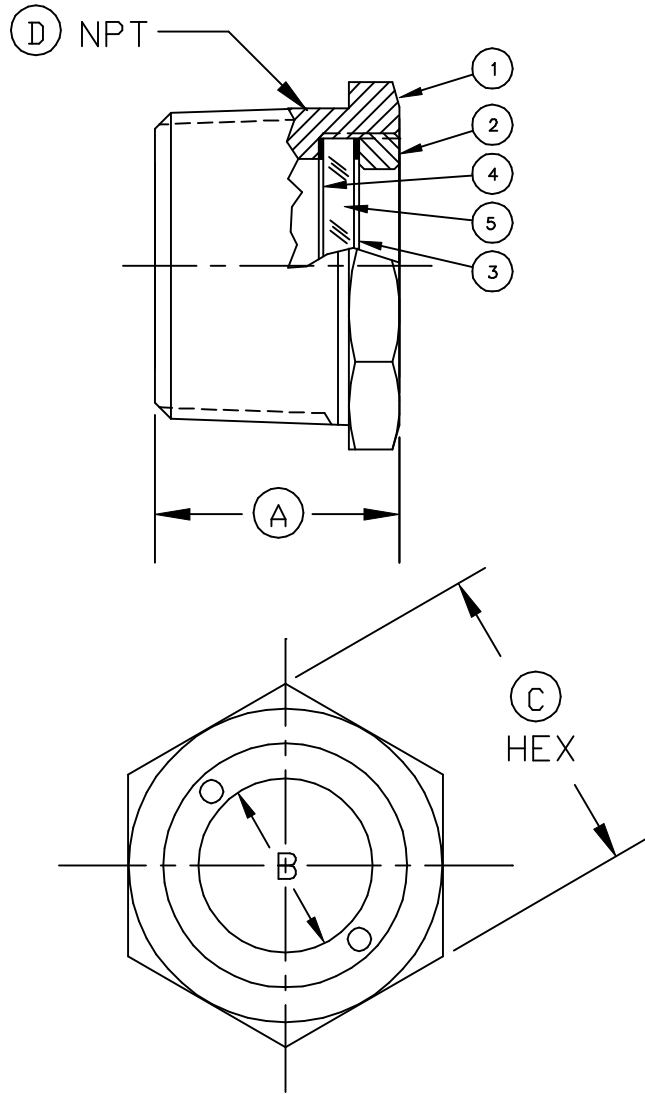

PARTS LIST				
PIECE NO.	NAME OF PART	QUAN.	MATERIAL	COMMENTS
1	BODY	1	SEE BELOW	
2	RETAINER	2	BRASS	
3	CUSHION	2	FIBER	
4	SEAL GASKET	2		
5	WINDOW	2	BOROSILICATE	

THIS DRAWING AND ALL INFORMATION ON IT IS THE PROPERTY OF JACOBY-TARBOX, DIVISION OF THE CLARK-RELIANCE CORPORATION. IT IS CONFIDENTIAL AND IS GIVEN TO YOU FOR A LIMITED PURPOSE AND MUST BE RETURNED UPON REQUEST. NEITHER THIS DRAWING NOR ANY PART OF IT NOR ANY INFORMATION CONCERNING IT MAY BE COPIED, EXHIBITED OR FURNISHED TO OTHERS NOR MAY PHOTOGRAPHS BE TAKEN OF ANY ARTICLE FABRICATED OR ASSEMBLED FROM THIS DRAWING WITHOUT CONSENT OF THE CLARK-RELIANCE CORPORATION.

TEMP F	150 PSIG MODELS	
	STEEL	316 SS
-20 TO 100	150	150
150	150	150
200	150	150
250	150	150
300	150	150
350	150	150
400	150	150
450	150	150
500	150	150

STANDARD DESIGN MATERIALS:

- BODY: AISI C1015 (CARBON STEEL)
- AISI A276 (316 SS)
- UNS C36000 H02 BRASS

OPTIONAL ALLOYS FURNISHED UPON REQUEST

RETAINER: UNS C36000 H02 BRASS
 316 SS RETAINER AVAILABLE

STYLE S-5400

DIMENSIONS								
D SIZE	A(IN)	A(mm)	B(IN)	B(mm)	C(IN)	C(mm)	WGT.(#)	WGT.(KG)
1	1.06	26.9	.625	15.9	1.50	38.1	2	.91
1-1/4	1.25	31.8	.875	22.2	1.75	44.4	3	1.36
1-1/2	1.31	33.3	1.06	26.9	2.00	50.8	3	1.36
2	1.44	36.6	1.31	33.3	2.50	63.5	3	1.36
2-1/2	1.69	42.9	1.75	44.4	3.00	76.2	4	1.81
3	1.75	44.4	2.38	60.4	3.50	88.9	4	1.81