

# RJ Boiler Gage Glass (900 PSI) Maintenance Instructions

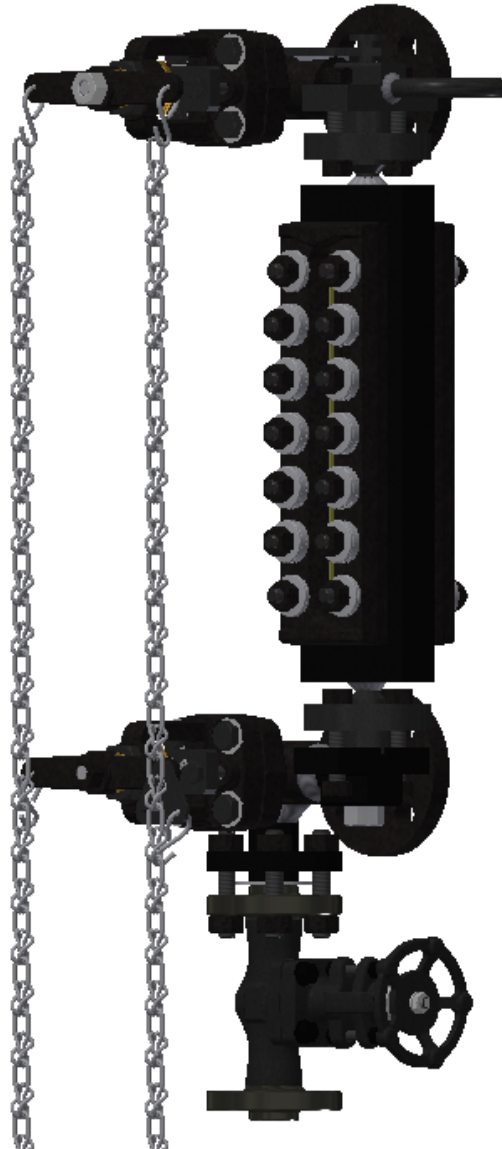

**Reliance®**

A PRODUCT OF CLARK-RELIANCE

**Caution:** Before proceeding, follow any and all plant lock-out/tag-out procedures required. Any trips/alarms should be bypassed to prevent any false trips/alarms when servicing the equipment. Verify that all power is turned off to any applicable equipment. If under pressure, the equipment should be isolated, or the boiler should be shut down before proceeding with the installation. Open drain valve to eliminate any trapped pressure. All inspection and installation steps should be performed by a qualified technician and should be executed in accordance with all applicable national and local codes and plant procedures.

Only use a properly calibrated torque wrench to guarantee that the specified torque values are achieved. Make sure all bolting is clean and lubricated per the applicable Reliance IOM.

### **Storage and Handling**

The Reliance® Commercial Boiler Gage Glasses meet or exceeds all applicable specifications when shipped from the factory. The equipment should be stored in an area protected from the elements and corrosive fumes, in a secure manner where they can neither fall, nor be struck by other objects. Avoid placing any objects on the valves or Boil-out Kit (if furnished) at any time. The temperature of the storage area should not exceed 150 degrees F. (65.5 degrees C) or drop below 32 degrees F (0 degrees C).

### **Unpacking and inspection**

Upon receipt of the Boiler Drum Level instruments, examine the contents of the container(s) for damage. Care should be exercised as the items are uncrated. The shipment may contain fragile glass components. Report any faulty conditions as soon as possible to your carrier to avoid acceptance of damaged goods. Clark-Reliance will not be responsible for goods damaged in shipping or storage, or subsequent loss or damage due to improper storage or exposure as a result of damage to shipping containers. Submit a digital photo of any damaged equipment and container to Clark-Reliance, if possible.

Verify that all materials are present as recorded on the Packing List provided with each shipment. Report any discrepancies to Clark-Reliance immediately. Have the Clark-Reliance order number and shipping waybill available at the time of your call.

### **Handling**

Your Clark-Reliance shipment has been carefully packed. However, the shipment may include spare parts, temporary water gages for “Boil-out” purposes, maintenance instructions, and engineering drawings. Upon receipt of the order, the equipment and above items should be identified and verified against the packing list. Any documentation that has been provided should be directed to the appropriate personnel.

### **Recommended Maintenance and Annual Inspections**

Regarding any recommended maintenance procedures or annual inspections, we suggest gage glasses should be inspected annually (at a minimum) for visual clarity, excessive corrosion, and leakage.

**Reliance®**  
A PRODUCT OF CLARK-RELiance

## Boil-out Gage Practice and Policy

On new boiler installations, it is common procedure to initially operate the boiler at a reduced pressure for a short time to 'cook out' foreign materials (pipe joint compound, grease, oil, flux, etc.) that remain in the drum or other pressurized parts of the system after the boiler has been constructed. During this boil-out period, most of the suspended or dissolved debris is flushed out with blow-down discharges. However, a small amount of residue is unavoidably deposited as a film on all internal wetted surfaces... including those of the water gage glass. This type of scum layer is nearly impossible to remove by blowing down the gage glass, particularly if the gage glasses are protected by mica shields, as they must be, in high pressure installations.

As a practical matter, it is more expedient to employ an inexpensive temporary level gage, which can be discarded or returned after the boil-out procedure, rather than to use then rebuild the gage glass intended for regular service. For boil-out purposes on new water columns, Clark-Reliance provides a temporary level gage at no charge, or at a refundable charge, under one of the following conditions:

1) When a commercial boiler gage glass and valve set are supplied and the boil-out pressure will not exceed 200 PSIG, Clark-Reliance automatically will furnish for temporary boil-out service the following parts at no charge for new boiler installations:

1 pc. – ¾" O.D. tubular glass gage cut to the proper length

2 pcs. – Rubber packing rings (\*)

1 pc. – Low visibility shield (so that low vision in the tubular glass gage is the same as in the gage glass that will be used for regular service).

At the conclusion of the boil-out procedure, all the above parts should be discarded. When the gage having stainless steel nipples is installed, it is essential that the appropriate (non-rubber) packing rings are used, to assure durable sealing of the stainless steel nipples.

2) When a gage glass having flanged connections is supplied as part of a water column, and the boil-out pressure will not exceed 200 PSIG, Clark-Reliance will furnish the following parts at no charge:

1 set – VB991 gage valves with ½" MNPT connections

1 pc. – 5/8" O.D. tubular glass gage cut to the proper length

1 pc. – Low visibility shield.

The boil-out gage valves should be temporarily installed in the ½" FNPT "Test" connections in the flanges of the regular water gage shut-off valves, which are on the water column. This equipment may be discarded after the boil-out has been completed.

3) On installations like the above, but where the boil-out pressure will exceed 200 PSIG, consult Clark-Reliance to discuss options for an appropriate temporary use gage and valves. The cost of this assembly will be listed separately on our order invoice. However, full credit will be issued upon its return to Clark-Reliance.

**Reliance**<sup>®</sup>  
A PRODUCT OF CLARK-RELiance

## **BEFORE YOU INSTALL THE GAGE GLASS:**

- Confirm that the gage glass model number and the pressure rating, which can be found on the nameplate, meet the required specifications and design conditions for the application.
- Support brackets should be considered for gages over four feet long and weighing in excess of 100 pounds. The support brackets will help prevent overloading of the connecting valves and piping. The brackets will also help prevent damage caused by excessive vibration.

### **Hot Torque Procedure**

When a new piece of equipment, whether a Gage Glass or a Probe type device is installed, the hot torque procedure must be performed. This ensures that all bolting and components are properly seated for optimum performance. This procedure must also be performed after any maintenance is done to the equipment. Note that only the affected components, such as the installation of a new probe or glass kit, need to be hot torqued.

All work must be done by a qualified technician. All plant rules and procedures must be followed, including any lock out / tag out requirements. Verify that all alarms and trips have been by-passed on probe columns before any maintenance is performed, to prevent any false alarms or wiring hazards.

The hot torque procedure should be performed as follows:

- 1) Isolate the gage glass or probe device from any pressure.
- 2) Fully open the drain valve to evacuate any built-up pressures and to allow the contained steam and water to escape during equipment warm up.
- 3) Slowly open the *steam valve* to allow a gentle rush of steam to flow through the equipment. Inspect the equipment to make sure there are no obvious leaks. This should take approximately 5 – 10 minutes. The observer should see the High Temperature lubricant “sizzling” and smoke emanating from the gage of column. This is an indication that the equipment has reached operating temperatures.
- 4) When the equipment has been properly heated, close the steam valve. The drain valve should remain open to allow any residual steam or pressure to escape.
- 5) Immediately re-torque the equipment to the correct values stated in the applicable instruction manual. There should be movement of approximately 1/8 of a turn or more.
- 6) If there is no movement of the bolting or probes, the equipment was not heated properly. Repeat the procedure.
- 7) Once the hot torque procedure is completed, close the drain valve, and the equipment can be put back into service. Carefully check for any leaks in the equipment and verify proper operation of all illumination, relay controls and wiring, or other accessories.

Refer to IOM R500.E239-A for additional information.

See the Hot Torque Procedure video online at  
<https://www.youtube.com/watch?v=THwWN5w64II>  
Or visit our website [RelianceBoilerTrim.com](http://RelianceBoilerTrim.com)

**Reliance**<sup>®</sup>  
A PRODUCT OF CLARK-RELIANCE

16633 Foltz Parkway • Strongsville, OH 44149 USA Telephone: +1 (440) 572-1500  
[www.clark-reliance.com](http://www.clark-reliance.com) • [sales@clark-reliance.com](mailto:sales@clark-reliance.com)

## **OPERATION INSTRUCTIONS**

The water level gage is ruggedly constructed to a well proven design and is equipped with the necessary safety devices to protect the operator. However, as with any pressure containing vessel, it should be treated with care and respect.

### **A. SETTING GAGE IN OPERATION**

(Bringing boiler and gage to pressure and temperature simultaneously)

A gage must increase uniformly in temperature as the pressure increases, but when left to itself, it will not do this. The gage is a bypass circuit and is heated only by steam in a very small channel. The water level is frequently high during the starting-up period so the steam space in the gage is correspondingly small; the result is that the gage temperature lags considerably behind the drum steam pressure. To avoid this temperature lag; keep the bottom shut-off valve open slightly and the top shut-off valve wide open. Then slowly open the drain valve to lower the water level until just visible. The drain valve should be shut occasionally to allow the water level to rise for examination. The object is to keep the gage full of steam so that its temperature will stay close to the drum temperature.

### **B. SETTING GAGE IN OPERATION**

(Boiler under operating conditions with gage cold)

With all valves closed, crack open the bottom shut-off valve and let water rise slowly in the gage (approximately six inches per minute). When the gage is completely full, close the bottom shut-off valve. After two or three minutes, open the drain valve and drain the gage slowly (at same rate as filled). When the gage is empty, close the drain valve and repeat this procedure at least five times. (The time element will vary from thirty minutes for an 18-INCH gage to an hour and forty minutes for a 60-INCH gage.) When the glass has been filled for the last time, open the bottom shut-off valve wide and crack open the top shut-off valve, letting the water level drop slowly until the level in the gage stabilizes. Open the top shut-off valve fully.

### **C. SETTING GAGE IN OPERATION**

(Boiler under operating conditions with gage hot)

The following procedure is to be used only when the gage has been removed from service for repairs of short duration. With all the valves closed, crack open the bottom shut-off valve and let the water rise slowly in the gage (approximately six inches per minute). When the gage is completely full, close the bottom shut-off valve. After two or three minutes, open the drain valve and drain the gage slowly (at same rate as filled). When the gage is empty, close the drain valve and crack open the bottom shut-off valve, letting the water level rise slowly as described above. When

# **Reliance®**

A PRODUCT OF CLARK-RELIANCE

16633 Foltz Parkway • Strongsville, OH 44149 USA Telephone: +1 (440) 572-1500  
[www.clark-reliance.com](http://www.clark-reliance.com) • [sales@clark-reliance.com](mailto:sales@clark-reliance.com)

the gage is completely full, open the bottom shut-off valve wide and crack open the top shut-off valve, letting the water level drop slowly until the level in the gage stabilizes. Open the top shut-off valve slowly until the full open position is reached.

#### D. **BLOWING DOWN GAGE GLASS**

Modern water condition practice makes it unnecessary to blow-down gages with a wide open valve. An orifice of 3/32 INCH diameter is ample blow-down area for gages above 900 PSIG. When blow-down of the gage appreciably lowers the gage glass pressure, it is likely to cause rapid deterioration of the mica. If small holes or cracks in the mica pack have permitted water to penetrate, suddenly lowered pressure permits this water to expand into steam and burst the mica, causing poor visibility. The rush of steam which occurs when blowing down through full drain areas may tear the mica.

Even with an orifice in the drain line, it is not advisable to blow the gage frequently. It should be blown down when necessary to clear out dirty water. During blow-down, the gage should be watched to see if the water level is lively as the blow starts and stops.

This indicates that the gage passages are clear. A gage blow-down procedure insuring maintenance of clear gage connections is as follows:

##### 1. BLOW-DOWN THROUGH THE TOP CONNECTION

With the top and bottom shut-off valves open and the drain valve closed, close the bottom shut-off valve and open the drain valve. This will confine all flow to the top connection and insure a clear passage. Close the drain valve and open the bottom shut-off valve.

##### 2. BLOW-DOWN THROUGH THE BOTTOM CONNECTION

With the top and bottom shut-off valves open and the drain valve closed, close the top shut-off valve and open the drain valve. This will confine all flow to the bottom connection and insure a clear passage. Close the drain valve and open the top shut-off valve.

**NOTE:** The shut-off valves should always be opened slowly and carefully whenever the gage assembly is under pressure.

It should be noted that the required frequency and duration of blow-down is dependent upon cleanliness of the boiler water, therefore the blow-down schedule and duration of the blow-down should be established by operating personnel through experience on the particular installation.

# **Reliance®**

A PRODUCT OF CLARK-RELIANCE

16633 Foltz Parkway • Strongsville, OH 44149 USA Telephone: +1 (440) 572-1500  
[www.clark-reliance.com](http://www.clark-reliance.com) • [sales@clark-reliance.com](mailto:sales@clark-reliance.com)

## Maintenance

### PREVENTIVE MAINTENANCE – GAGE

Check the gage assembly for signs of leakage. Even minor seepage, if allowed to continue, may result in cutting of seating surfaces necessitating machining of the piece. If leakage is detected, the gasket loading should be checked as follows:

With torque wrench set at 40 FT-LB, go over nuts following sequence shown in Figure 2. ***The pressure in the gage should be relieved before any retightening is attempted.*** If leakage continues after retightening, the section should be disassembled, and the parts examined to determine a reason other than washer loading for the continued leakage. Carefully examine the seating surface for steam cuts. Examine the impression in the gasket to determine that the glass was properly centered and evenly loaded. After correcting the difficulty reassemble the section using new gasket, new cushion, new mica, and new glass.

The water level gage should be isolated from the vessel and repaired whenever:

- 1) The mica becomes too fouled for observing level,
- 2) The glass becomes cloudy indicating mica failure and glass deterioration Or
- 3) Leakage around the glass inserts is observed which cannot be corrected by checking gasket loading as described above.

### CORRECTIVE MAINTENANCE – GAGE

It is best to dismantle the gage while hot as gasket sticking is reduced to a minimum. To dismantle the gage, the nuts and spring washers at the ends of the cover should be removed first. The remaining nuts and washers are then removed following the sequence shown in Figure 1. Before removing the cover plate, carefully mark its position on the chamber so that it can be replaced in its original position at reassembly. Remove the cover plate, glass and mica. Remove the gasket being careful not to damage the chamber-seating surface. If tools must be used to overcome sticking, a broad, flat brass scraper should be used. Carefully clean all gasket material from the gasket seat. Remove the cushion from the cover plate, taking the same precautions as observed in removing the gasket. New gaskets and cushions should always be used in reassembly of the gage since a glass not seated in the identical depressions left previously would create a condition of point loading under which the glass would readily fail. New mica should always be used. Even if the old mica can be thoroughly cleaned and looks satisfactory, cracks may develop during cleaning, which will allow water to penetrate to the glass. Although a used glass may look perfect, it may have lost some of its original temper. Therefore, the glass must also be replaced when dismantling and reassembling a gage.

Assemble the gage as follows:

Centralize the glass insert so that it uniformly clears the sides of the recess

**Reliance**<sup>®</sup>  
A PRODUCT OF CLARK-RELIANCE

(See Figure 3). A piece of 1/64 INCH gasket material, 1-1/2 INCH long by 3/8 INCH wide should be placed as a spacer at each end of the glass to prevent contact with the chamber and to assist in centralizing the glass in its seat. Use new parts for glass insert, mica protector, gasket (1/32 INCH thick), cushion for cover plate (1/32 INCH thick), washer set and old cover plate and nuts. Four (4) spring washers (P/N: V-15697-J1) are to be stacked under each nut on the bolts as shown in Figure 2B and two (2) spring washers are to be stacked under each nut on the studs as shown in Figure 2A.

**NOTE:**

In order to obtain the correct results, the washer orientation must be exactly as shown in Figures 2A and 2B

Be sure the cover is firmly seated. Turn all nuts finger tight, following the sequence shown on Figure 2, repeating this procedure twice. Do not go over the nuts more than twice. **NOTE: IT IS IMPORTANT THAT THE COVER BE DRAWN DOWN EVENLY.** Using a torque wrench set for 10 FT-LB, tighten nut No. 1, then work outward following the sequence shown in Figure 2 until all bolt nuts are tightened. Repeat this procedure, increasing torque by 10 FT-LB increments until a uniform torque of 40 FT-LB is reached.

Reset torque wrench to 10 FT-LB and repeat the above procedure on the stud nuts – first, tighten stud nuts on one end and then the other; both front and rear of gage to 10 FT-LB. Proceed as with the bolts, tightening the stud nuts in 10 FT-LB increments until all nuts are torque to 40 FT-LB.

**NOTE: ALL THREADED SURFACES SHOULD BE PROPERLY LUBRICATED TO ENSURE PROPER GASKET LOADING.**

**WARNING:**

The foregoing instructions are based on the use of grafoil gaskets, (P/N: V-13488-7) and Garlock IFG5500 cushions (inorganic fiber gasket), (P/N: V-18980-7). The washers are springs and will compensate for bolt elongation, due to thermal expansion and for gasket set, so that further tightening should not be necessary. If these instructions are carefully followed, all nuts should draw up evenly on the last adjustment because of uniform loading. Gross differences should be investigated.

**PREVENTATIVE MAINTENANCE – VALVES**

A periodic check of all valve joints should be made and all leakage corrected immediately. Discovery of leaks at an early stage will considerably prolong valve life. Proper maintenance of packing and corrected adjustment of packing glands are essential to satisfactory valve stem life and good valve performance. New packing lubricates the stem; after this lubricant disappears, friction between stem and packing increases. If the packing cap screws must be tightened to a point where it is difficult to turn the stem, the packing has become dry and hard or it is unsuitable for service. In either case it should be discarded as it imposes an additional

**Reliance®**

A PRODUCT OF CLARK-RELIANCE

16633 Foltz Parkway • Strongsville, OH 44149 USA Telephone: +1 (440) 572-1500  
[www.clark-reliance.com](http://www.clark-reliance.com) • [sales@clark-reliance.com](mailto:sales@clark-reliance.com)



burden that will rapidly shorten stem thread life. If a packing joint leaks too much, tighten each cap screw only one turn and then wait for about ten minutes to allow packing to adjust itself and reduce excessive leakage. Repeat this procedure until leakage is eliminated. Stem packing that has been subjected to high temperature steam and then allowed to cool often leaks a small amount when the valve goes back into operation. It does not necessarily call for adjustment of packing gland; as soon as the valve becomes hot it will in most cases stop leaking.

## **CORRECTIVE MAINTENANCE – VALVES**

Be sure to relieve internal valve pressure before performing maintenance on valves (See Figure 4).

### **REPACKING THE VALVES**

Remove packing gland cap screws and slide packing gland back on the stem. Remove old packing, being careful not to damage stuffing box or stem with the packing tool.

Be sure all old packing has been removed and that the stuffing box is clean. New packing should be installed by seating each ring individually. If seating of the complete pack of rings is done simultaneously by the gland, the rings nearest the gland will be overloaded and the bottom rings may do no sealing whatsoever. Packing ring joints should be staggered 90 degrees apart. Replace the packing gland and cap screws in position, tighten firmly and evenly with a wrench and then back off and adjust to finger tight.

### **REGRINDING THE SEAT**

Backseat stem by fully opening valve. Disengage bushing nut. Remove packing gland cap screws and slide packing gland back on the stem. Remove packing, position stem in yoke to permit rotating of the bushing. Rotate bushing until it rests against the unrelieved portion of the stem. Mark position of yoke on valve body. Remove the yoke holding cap screws, remove yoke assembly from the valve, remove and discard spiral gasket.

Apply grinding compound to the back seating surface of the stem. Pull stem back against the yoke and grind back seat by rotating the handwheel. Apply additional grinding compound as required to complete the regrinding. Apply grinding compound to the seating surface of the stem and assemble yoke to valve body being careful to replace yoke in its original position as marked. Only two (2) cap screws need to be used to tighten yoke in position for grinding. Push stem down on valve seat and regrind by rotating the handwheel.

When grinding has been completed, remove the yoke assembly from the valve and clean all compound from the stem and seat. Swab the area with a clean, lintless cloth, saturated with a volatile solvent (acetone) and clean with demineralized or distilled water before the solvent dries. As an aid to assembly, and to future disassembly, Neolube or an equivalent lubricant may be applied to the threaded parts. (Neolube is a suspension of colloidal electric furnace graphite in isobutyl alcohol.) One coat of Neolube should be applied with a soft brush and

# **Reliance®**

A PRODUCT OF CLARK-RELIANCE

16633 Foltz Parkway • Strongsville, OH 44149 USA Telephone: +1 (440) 572-1500  
[www.clark-reliance.com](http://www.clark-reliance.com) • [sales@clark-reliance.com](mailto:sales@clark-reliance.com)

allowed to dry for five minutes before assembly. It should be used only where deemed necessary and then only on surface which make actual metal-to-metal contact.

Reassemble the valve using a new spiritallic gasket and repack following the instructions under Paragraph E (REPACKING THE VALVE). Perform a hydrostatic test if possible to check the seating surfaces for leakage (See Paragraph D – TESTS – under II – INSTALLATION INSTRUCTIONS).

## RENEWING THE SEAT

Remove the yoke assembly and spiritallic gasket from the valve. Discard the spiritallic gasket. Using a standard 3/8" allen wrench, remove the seat and remove the seat gasket. Apply Neolube to the new seat threads following the instructions in Paragraph F (REGRINDING THE SEAT), and replace the seat and new gasket in the valve body. Tighten well to prevent leakage around the seat threads. Reassemble the valve as instructed in Paragraph F (REGRINDING THE SEAT).

## II REMACHINING PROCEDURE FOR REPAIR OF GASKET SEATS

### A. GENERAL

Remachining of defects in the gasket seats of gage chamber should be performed only if emergency conditions necessitate that it be done to keep the gage serviceable.

Gasket seat defects are caused by steam cuts due to steam leaks not detected during routine preventative maintenance checks or gouges caused by careless removal of gaskets or subsequent handling of gasket seats during the maintenance of gage chamber.

### B. PROCEDURE

1. Disassemble and remove old gaskets following the instructions under (See Paragraph B – CORRECTIVE MAINTENANCE-GAGE under IV – MAINTENANCE.
2. Remove stud tack weld by grinding or machining as required taking care not to damage chamber threads and seating surfaces. Remove all studs from chamber.
3. A milling machine using a 1-3/8 INCH diameter cutter as shown in Figure 5, is required to remachine the gasket seating surfaces.
4. The maximum allowable depth for remachining the gasket seat in chamber is as shown in Figure 6. Do not remove any more material than necessary to eliminate defect.
5. After remachining gasket seat, clean and deburr chamber.
6. Install and tack weld new studs in chamber as shown in Figure 7.
7. Reassemble gage following the instructions under (See Paragraph B – CORRECTIVE MAINTENANCE-GAGE under

# Reliance®

A PRODUCT OF CLARK-RELIANCE

16633 Foltz Parkway • Strongsville, OH 44149 USA Telephone: +1 (440) 572-1500  
[www.clark-reliance.com](http://www.clark-reliance.com) • [sales@clark-reliance.com](mailto:sales@clark-reliance.com)

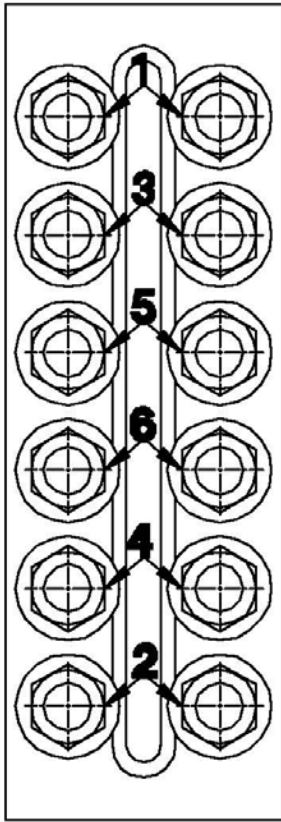

TO DISASSEMBLE  
FIGURE 1

END STUDS (SEE FIG. 2A)

TIGHTEN THESE NUTS  
 FRONT AND BACK ON  
 BOTH ENDS, 80 FT-LBS  
 IN SEVEN STEPS, AFTER  
 TIGHTENING BOLT NUTS.  
 (SEE TEXT)

BOLTS (SEE FIG. 2B)

TIGHTEN NUTS TO  
 80 FT-LBS IN SEVEN  
 STEPS.  
 (SEE TEXT)

END STUDS (SEE FIG. 2A)

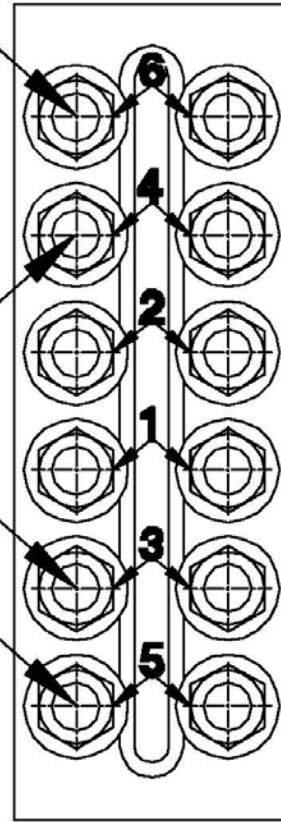

TO ASSEMBLE  
FIGURE 2

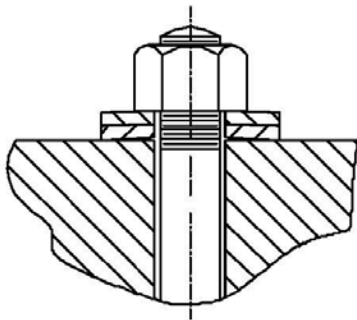

SPRING WASHER STACK  
 UNDER EACH STUD NUT

FIGURE 2A

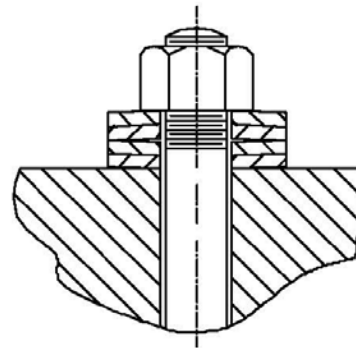

SPRING WASHER STACK  
 UNDER EACH BOLT NUT

FIGURE 2B

# Reliance®

A PRODUCT OF CLARK-RELIANCE

16633 Foltz Parkway • Strongsville, OH 44149 USA Telephone: +1 (440) 572-1500  
[www.clark-reliance.com](http://www.clark-reliance.com) • [sales@clark-reliance.com](mailto:sales@clark-reliance.com)

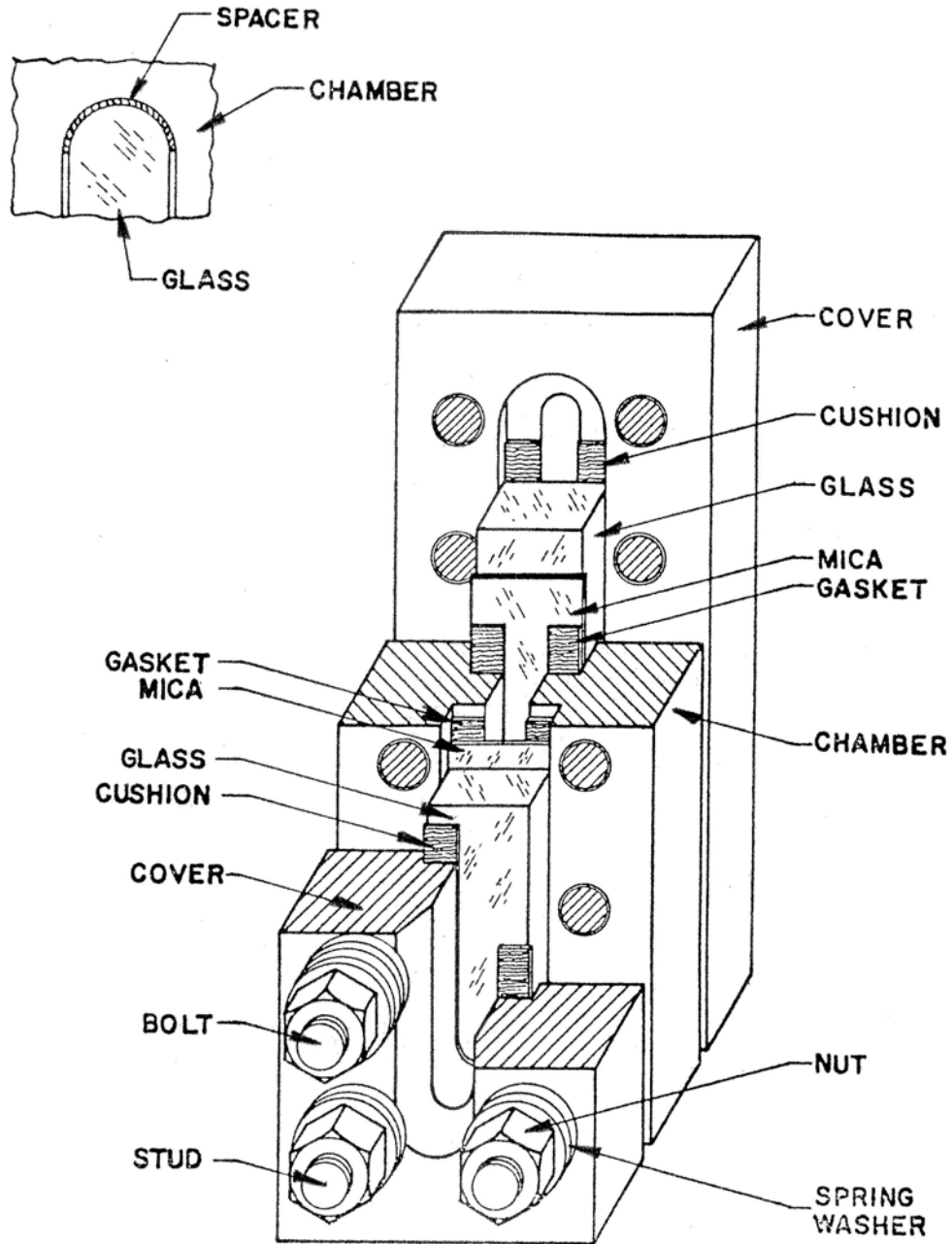

FIGURE 3

**AN OBLIQUE SECTIONAL  
VIEW OF A TYPICAL BOILER  
WATER GAGE SECTION**

**Reliance®**

A PRODUCT OF CLARK-RELIANCE

16633 Foltz Parkway • Strongsville, OH 44149 USA Telephone: +1 (440) 572-1500

[www.clark-reliance.com](http://www.clark-reliance.com) • [sales@clark-reliance.com](mailto:sales@clark-reliance.com)

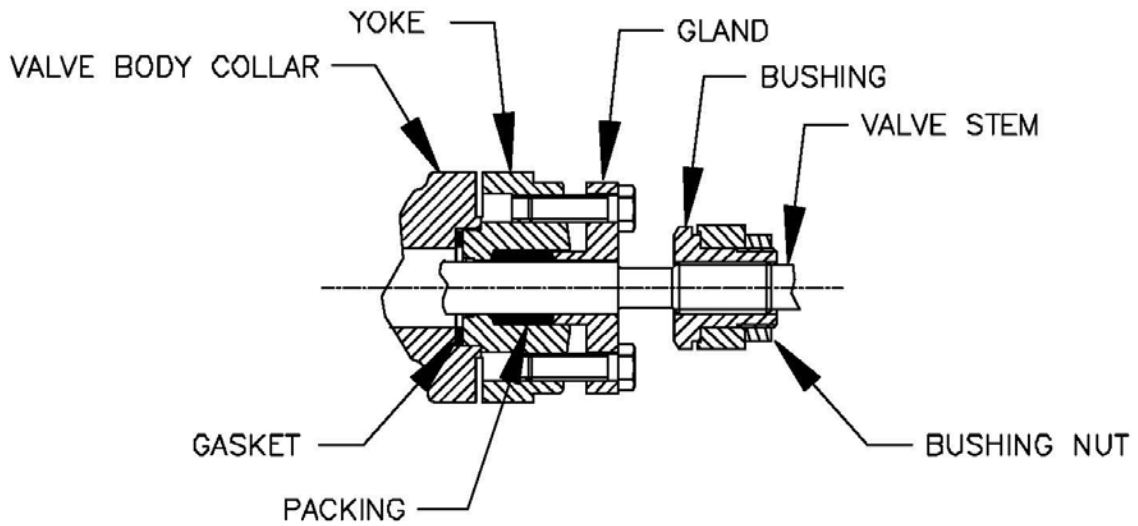
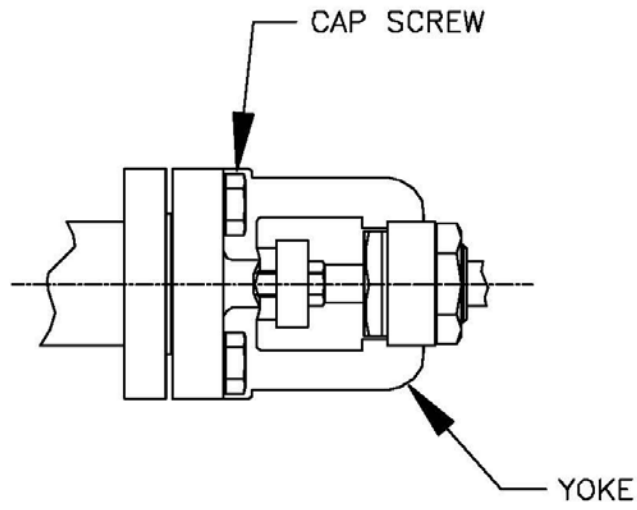

FIGURE 4

**Reliance**<sup>®</sup>

A PRODUCT OF CLARK-RELIANCE

16633 Foltz Parkway • Strongsville, OH 44149 USA Telephone: +1 (440) 572-1500  
[www.clark-reliance.com](http://www.clark-reliance.com) • [sales@clark-reliance.com](mailto:sales@clark-reliance.com)

NOTE:  
 1-3/8 INCH O.D. END MILL MUST  
 BE PERPENDICULAR TO GASKET  
 SEATING SURFACE TO BE MACHINED.

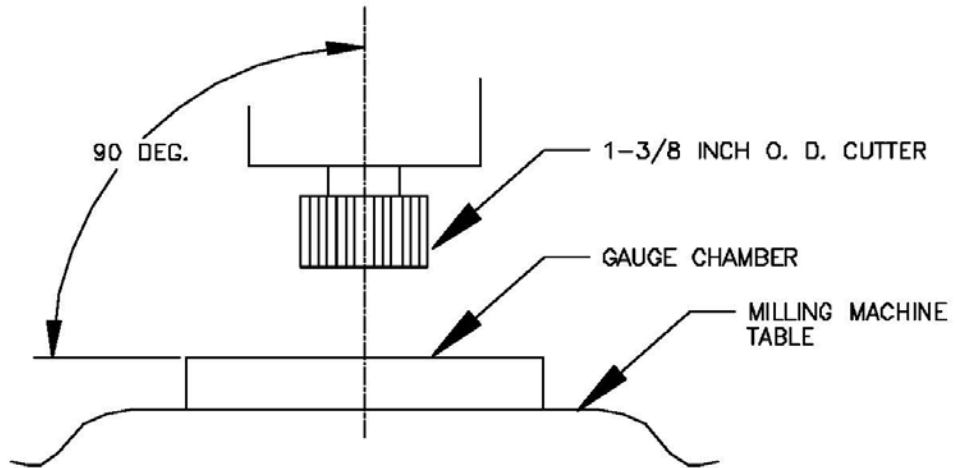

FIGURE 5

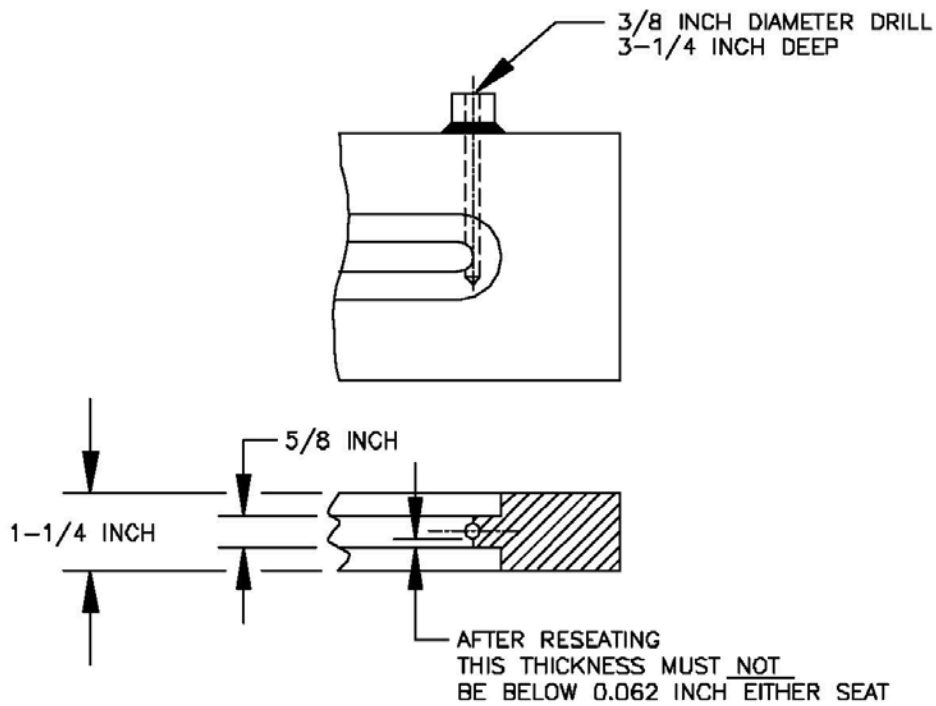

FIGURE 6

**Reliance**<sup>®</sup>

A PRODUCT OF CLARK-RELIANCE

16633 Foltz Parkway • Strongsville, OH 44149 USA Telephone: +1 (440) 572-1500  
[www.clark-reliance.com](http://www.clark-reliance.com) • [sales@clark-reliance.com](mailto:sales@clark-reliance.com)

NOTE:  
STUD MATERIAL IS 4140 STEEL.  
CHAMBER MATERIAL IS CARBON STEEL.  
A WELD ROD COMPATIBLE WITH  
ABOVE MATERIALS SHOULD BE  
SELECTED FOR TACK WELDING OPERATION.

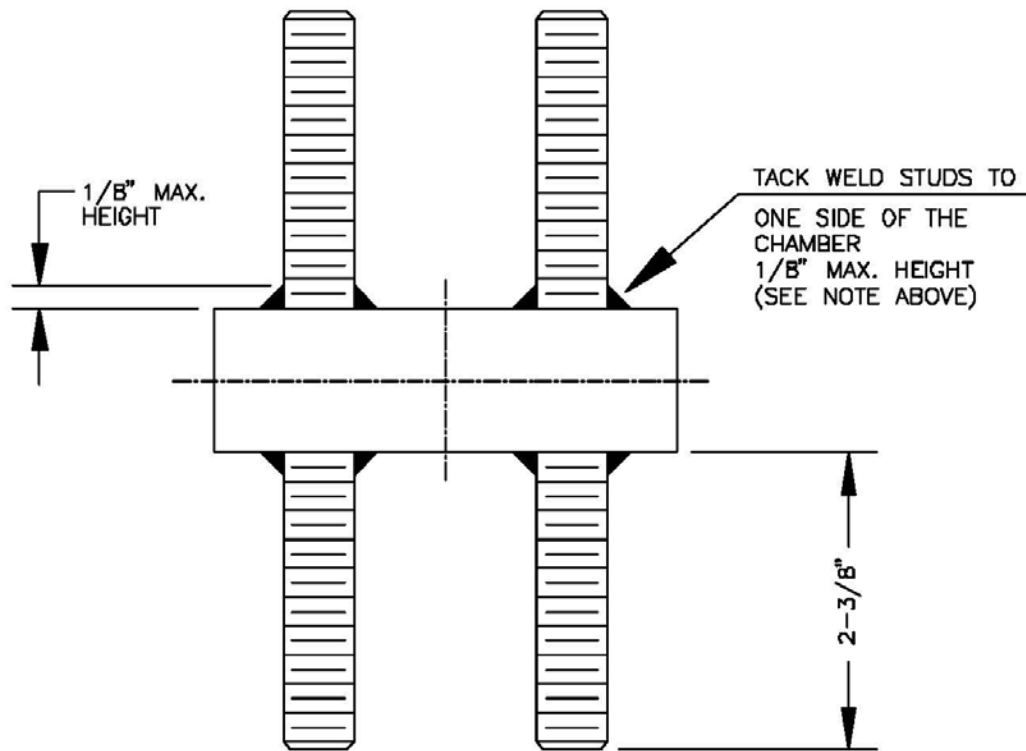

FIGURE 7

**Reliance**<sup>®</sup>

A PRODUCT OF CLARK-RELIANCE

16633 Foltz Parkway • Strongsville, OH 44149 USA Telephone: +1 (440) 572-1500  
[www.clark-reliance.com](http://www.clark-reliance.com) • [sales@clark-reliance.com](mailto:sales@clark-reliance.com)

## Recommended Spare Parts

<b>RJSG 900 Series Commercial Gage Glass and Valve Set</b>			
<b>Part No.</b>	<b>Rating</b>	<b>Description</b>	<b>Quantity Needed Per Section</b>
JSG189B-KIT	1100 WSP 1600 WSP	Repair Kit (HP Glass, Seal & Cushion Gasket, Mica Shield)	2
V15528-J1		Spring Washer	Each
P3924		Chain (Chainwheel-Operated Valves)	Per Foot
V13488-7		Gasket, Gafoil	2
G264		Stem Packing, Graphite	12 Required per Valve

**Reliance**<sup>®</sup>  
A PRODUCT OF CLARK-RELIANCE

16633 Foltz Parkway • Strongsville, OH 44149 USA Telephone: +1 (440) 572-1500  
[www.clark-reliance.com](http://www.clark-reliance.com) • [sales@clark-reliance.com](mailto:sales@clark-reliance.com)



**REPLACEMENT PARTS WARNING**

THE USE OF NON-ORIGINAL EQUIPMENT MANUFACTURER PARTS (SUCH AS GLASS, GASKETS, PROBES, MODULES, ETC.) WILL VOID THE AGENCY APPROVAL (FM, UL, CAS, CRN, ABS, ETC.) PRESSURE/TEMPERATURE RATING, AND WARRANTY OF THE EQUIPMENT. CLARK-RELIANCE REQUIRES THE USE OF OEM PARTS FOR ALL REPAIRS IN ON THIS PRODUCT IN ORDER TO MAINTAIN PLANT AND PERSONNEL SAFETY, AND RELIABLE OPERATION.

Consult the factory or your local Clark-Reliance Representative with any questions. Please have the model numbers and/or reference drawing numbers available when calling. You can also contact us at our website [www.relianceboilertrim.com](http://www.relianceboilertrim.com) or [RelianceAppEng@clark-reliance.com](mailto:RelianceAppEng@clark-reliance.com).



**On-Line Parts – DIRECT – for Clark-Reliance Products**

**JERGUSON® Reliance®**

**JACOBY-TARBOX® MAGNE-SONICS®**



**[www.clark-reliance.com/parts](http://www.clark-reliance.com/parts)**

**Reliance®**  
A PRODUCT OF CLARK-RELIANCE