

THIS DRAWING AND ALL INFORMATION ON IT IS THE PROPERTY OF THE CLARK-RELIANCE CORPORATION. IT IS CONFIDENTIAL AND IS GIVEN TO YOU FOR A LIMITED PURPOSE AND MUST BE RETURNED UPON REQUEST. NEITHER THIS DRAWING NOR ANY PART OF IT NOR ANY INFORMATION CONCERNING IT MAY BE COPIED, EXHIBITED OR FURNISHED TO OTHERS NOR MAY PHOTOGRAPHS BE TAKEN OF ANY ARTICLE FABRICATED OR ASSEMBLED FROM THIS DRAWING WITHOUT CONSENT OF THE CLARK-RELIANCE CORPORATION.



JACOBY-TARBOX®

A Product of the Clark-Reliance Corporation

16633 FOLTZ PARKWAY
STRONGSVILLE, OH 44149 USA
PH: +1 440-572-1500
www.clark-reliance.com

SIGHT FLOW INDICATOR MODEL 90-LR, 90-LR-D ASME CLASS 150 SERVICE

SECTION: **T400**
BULLETIN: **T400.107**
DATE: **3/5/2020**
SUPERSEDES: **8/16/2018**
FILE NO.: **T400-107.DWG**
DRAWN: **MWS** | CHECKED: **DEP**
SCALE: **NONE**

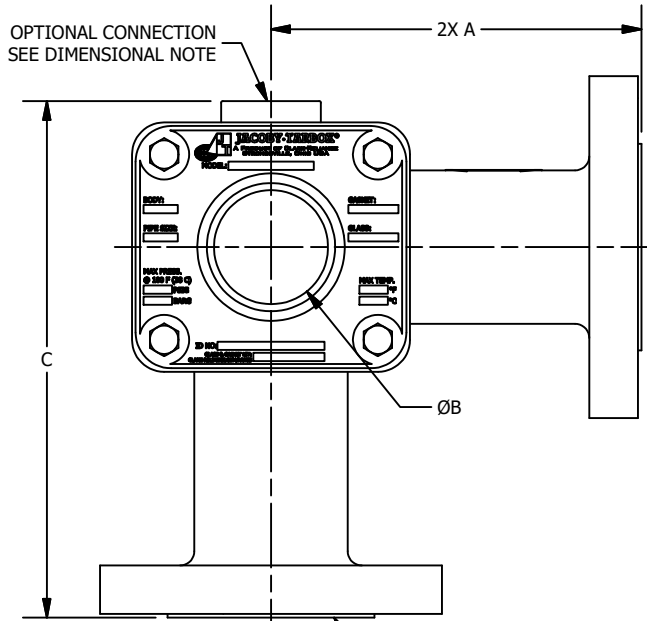

FACED AND DRILLED TO ASME B16.5 CL150 DIMS

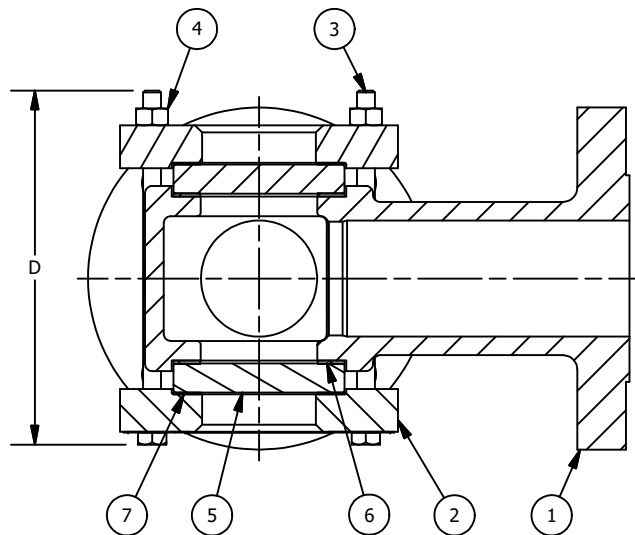

PARTS LIST			
PIECE NO.	PART NAME	QTY.	STANDARD DESIGN MATERIALS
1	BODY (SEE NOTE (1))	1	ASTM A216-WCB (CARBON STEEL) ASTM A351-CF8M (316 SS)
2	RETAINER (2)	2	ASTM A216-WCB (CARBON STEEL)
3	BOLT (2)	4	ASTM A354-BD (ALLOY STEEL)
4	NUT (2)	4	ASTM A194-2H (ALLOY STEEL)
5	WINDOW (3)	2	TEMPERED BOROSILICATE
6	SEAL GASKET (4)	2	NEOPRENE
7	CUSHION GASKET	2	FIBER
8	INDICATOR	1	NO INDICATION DRIP TUBE (316SS)

NOTES (REFERENCE PARTS LIST)

(1) a. STANDARD FLANGES FACED & DRILLED TO ASME B16.5 CLASS 150 RF DIMENSIONS
b. ADDITIONAL ALLOYS AVAILABLE PER REQUEST
c. OPTIONAL PFA (TEFLON) LINING PER T400.307

(2) ADDITIONAL ALLOYS AVAILABLE PER REQUEST

(3) a. OPTIONAL MATERIALS AVAILABLE PER PROCESS CONDITIONS
b. ADDITIONAL WINDOW OPTIONS AVAILABLE SEE SIDE SECTION FOR DETAILS

(4) COMMON OPTIONAL SEAL MATERIALS AVAILABLE

<input type="checkbox"/> PTFE	<input type="checkbox"/> GRAPHITE	<input type="checkbox"/> FIBER
-------------------------------	-----------------------------------	--------------------------------

DESIGNED IN ACCORDANCE WITH ASME B31.1 & B31.3 FOR PRESSURE VERSUS TEMPERATURE RATINGS USING ONLY LISTED METALS IN FABRICATION

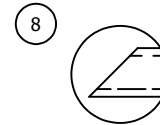
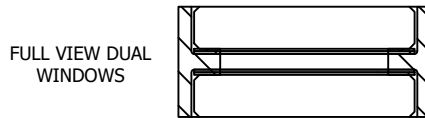
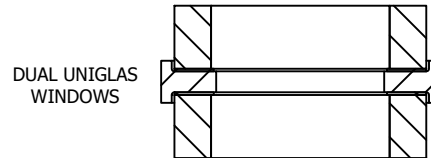
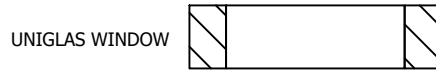

DRIP TUBE
MODEL 90-LR-D

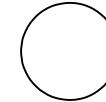

NO INDICATOR
MODEL 90-LR



ASME PRESSURE / TEMP RATINGS		
PSIG / °F (BAR / °C)		
TEMP °F (°C)	PRESSURE	
	STEEL	316 SS
-20 TO 100 (-29 TO 37)	285 (19.65)	275 (18.96)
150 (66)	270 (18.61)	255 (17.58)
200 (93)	260 (17.92)	235 (16.20)
250 (121)	245 (16.89)	225 (15.51)
300 (149)	230 (15.86)	215 (14.82)
350 (177)	215 (14.82)	205 (14.13)
400 (204)	200 (13.79)	195 (13.44)
450 (232)	185 (12.76)	180 (12.41)
500 (260)	170 (11.72)	170 (11.72)

FOR TEMPERATURES ABOVE 500°F (260°C) REFER TO ASTM B16.5 FOR PRESSURE RATINGS

FLANGE SIZE		A		B		C		D (**)		APPROX. WEIGHT	
IN	DN	IN	mm	IN	mm	IN	mm	IN	mm	LBS	KGS
1	25	5.00	127	1.25	32	6.88	175	4.67	119	7	3.2
1 1/2	40	6.00	152	2.00	51	8.38	213	6.20	158	15	6.8
2	50	6.50	165	2.00	51	9.06	230	6.20	158	26	11.8
3	80	7.75	197	3.18	81	11.13	283	8.30	211	48	21.8
4	100	9.00	229	4.25	108	13.16	334	9.83	250	70	31.8
6	150	11.50	292	6.38	162	16.97	431	14.50	368	155	70.3

DIMENSIONS (TOL ± .125 (3mm))

(**) STANDARD BOLT LENGTH SHOWN. OPTIONAL WINDOW MATERIALS OR USE OF STUDS MAY INCREASE LENGTH

DIMENSIONAL NOTE: 1/2", 3/4", AND 1" VENT CONNECTIONS AVAILABLE IN FEMALE NPT, MALE NPT, OR FLANGED CONNECTIONS. SEE BULLITON T100.90 TO CONFIGURE.

