

# ANDERSON™

A Division Of The Clark-Reliance Corporation

## Line Type Models L, LC, LCF, LCR, LCC, LCCR Separators

Section:	A100
Bulletin:	A100.50
Date:	9/1/96
Supersedes:	3/88

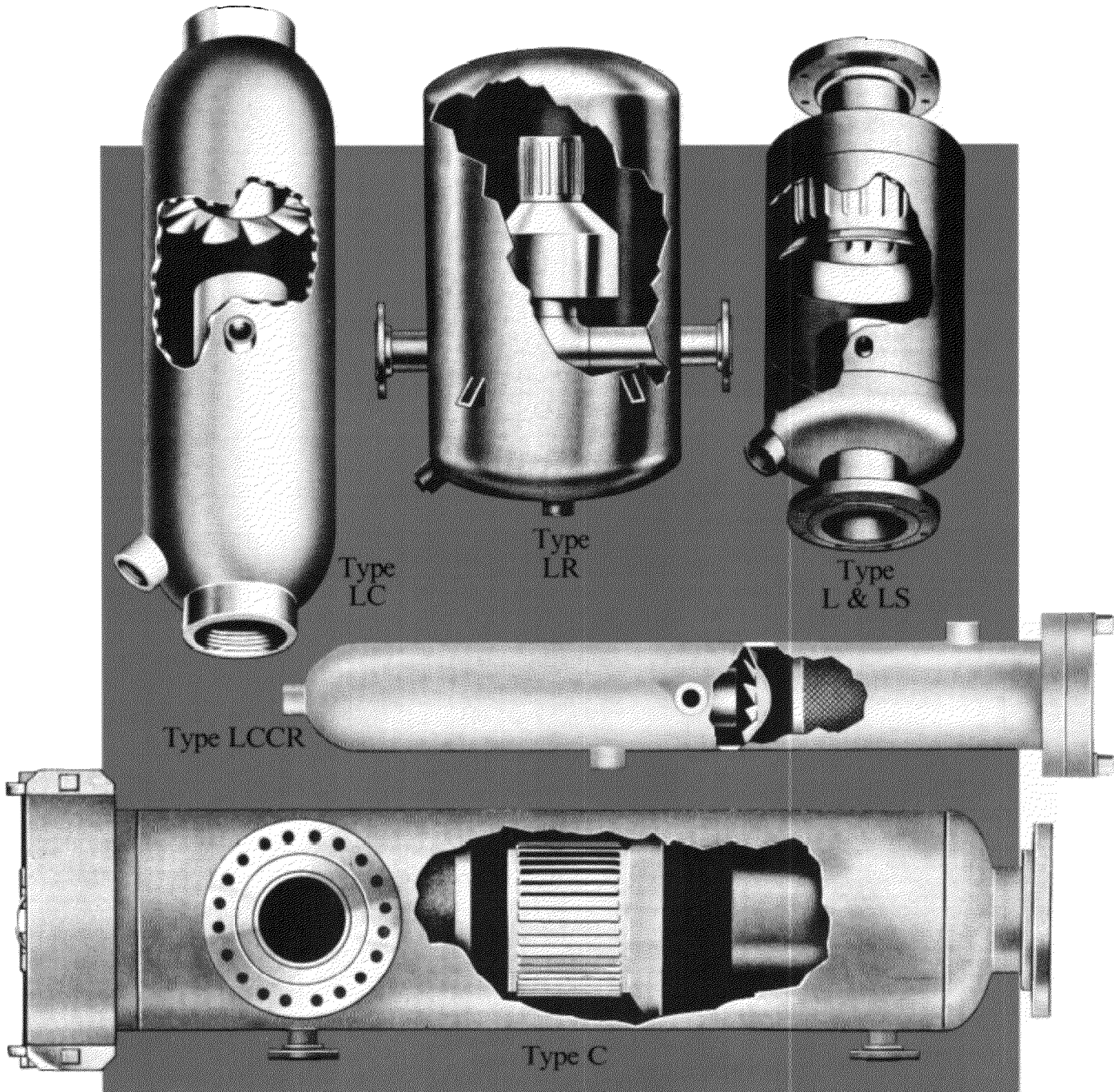

# ANDERSON SEPARATOR

## Line Type LC, LCF, LCR, LCC, & LCCR Separators

Anderson Type LC, LCF, and LCR Separators are designed to eliminate 99% plus of all liquid entrainment of 10 microns and larger. Type LCC and LCCR are designed to eliminate 99.9% of all liquid entrainment of 1 micron and larger from air,

gas, steam and vapor pipe lines without causing any significant pressure drop.

These separators are available for immediate shipment from stock for installations up to 600 PSIG and 500°F.

### LC Separators

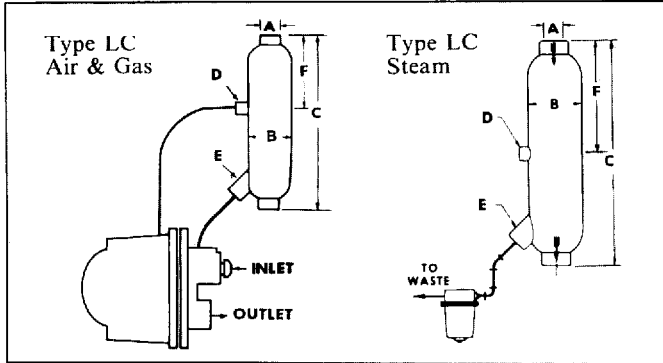

Dimensions in inches

TYPE		LC 25	LC 50	LC 75	LC 100	LC 125	LC 150	LC 200
Pipe Size	A	1/4	1/2	3/4	1	1 1/4	1 1/2	2
Diameter	B	2 1/4	2 1/4	2 1/4	3 1/4	3 1/4	5	5
Length	C	8 3/4	8 3/4	8 3/4	14 5/8	14 5/8	16 5/8	16 5/8
Vent Size	D	1/4	1/4	1/4	1/4	1/4	1/4	1/4
Drain Size	E	1/2	1/2	1/2	3/4	3/4	3/4	3/4
Vent Location	F	3 1/2	3 1/2	3 1/2	6 1/8	6 1/8	8 1/8	8 1/8
Weight		4#	4#	4#	8#	8#	18#	18#

### LCF Separators

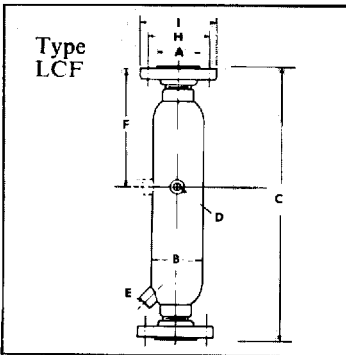

Dimensions in inches

TYPE		LCF 50		LCF 75		LCF 100		LCF 125		LCF 150		LCF 200	
Flange Rating		150	300	150	300	150	300	150	300	150	300	150	300
Pipe Size	A	1/2	1/2	3/4	3/4	1	1	1 1/4	1 1/4	1 1/2	1 1/2	2	2
Diameter	B	2 1/4	2 1/4	2 1/4	2 1/4	3 1/4	3 1/4	3 1/4	3 1/4	5	5	5	5
Length	C	10 1/2	11	10 3/4	11 1/2	16 5/8	17 3/8	17 1/8	17 5/8	19 1/2	20 1/8	20	20 5/8
Vent Size	D	1/4	1/4	1/4	1/4	1/4	1/4	1/4	1/4	1/4	1/4	1/4	1/4
Drain Size	E	1/2	1/2	1/2	1/2	3/4	3/4	3/4	3/4	3/4	3/4	3/4	3/4
Vent Location	F	4 1/2	4 5/8	4 5/8	5	7 5/8	8	8	8 1/8	10 1/4	10 1/2	10 1/2	10 3/4
Diameter of Bolt Hole Ring	H	2 3/8	2 5/8	2 3/4	3 1/4	3 1/8	3 1/2	3 1/2	3 7/8	3 7/8	4 1/2	4 3/4	5
Diameter of Flange	I	3 1/2	3 3/4	3 7/8	4 5/8	4 1/4	4 7/8	4 5/8	5 1/4	5	6 1/8	6	6 1/2
Weight		8#	10#	8#	10#	12#	14#	14#	16#	24#	30#	28#	32#

### LCR Separators

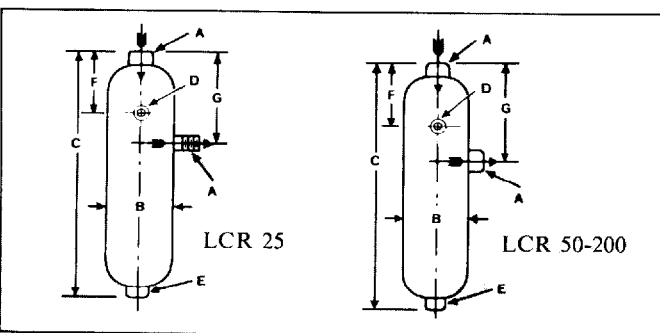

Dimensions in inches

TYPE		LCR 25	LCR 50	LCR 75	LCR 100	LCR 125	LCR 150	LCR 200
Pipe Size	A	1/4*	1/2	3/4	1	1 1/4	1 1/2	2
Diameter	B	2 1/4	2 1/4	2 1/4	3 1/4	3 1/4	5	5
Length	C	8 3/16	19	19	24	24	25	25
Vent Size	D	1/4	1/4	1/4	1/4	1/4	1/4	1/4
Drain Size	E	1/4	1/2	1/2	3/4	3/4	3/4	3/4
Vent Location	F	2 3/4	3 7/8	4	6 1/4	6 3/8	8 1/4	3 3/4
Outlet Location	G	4 3/4	5 7/8	6	9	9 3/8	11 3/4	11 7/8
Weight		4#	6#	6#	11#	11#	24#	24#
Reservoir - PTS		1/2	1 1/4	1 1/4	3 3/4	3 3/4	6 1/2	6 1/2

\*Outlet Conn. 1/4" Male



# Vertical Type LCC & LCCR Separators

Anderson LCC and LCCR vertical separators employ a specially designed coalescer element to remove finely divided liquid particles as minute as 1 micron from air, steam, gas or vapor lines.

These models are available for immediate shipment from stock for installations up to 600 PSIG and temperatures to 300°F. Also available for steam service up to 500°F.

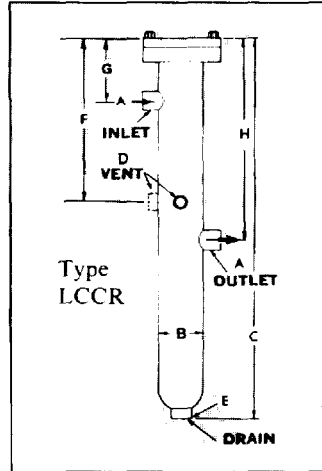
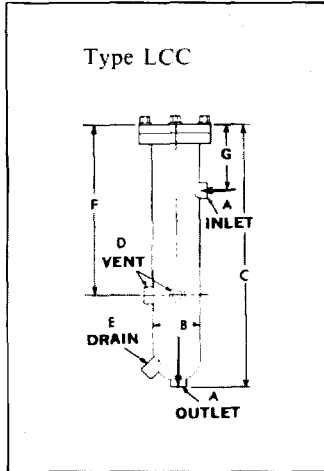

Dimensions in inches

TYPE	LCC 25	LCC 50	LCC 75	LCC 100	LCC 125	LCC 150	LCC 200
Pipe Size	A 1/4	1/2	3/4	1	1 1/4	1 1/2	2
Diameter	B 2 1/4	2 1/4	2 1/4	3 1/4	3 1/4	5	5
Length	C 13 1/2	13 1/2	13 1/2	18 1/4	18 1/4	19 5/8	19 5/8
Vent Size	D 1/4	1/4	1/4	1/4	1/4	1/4	1/4
Drain Size	E 1/4	1/2	1/2	3/4	3/4	3/4	3/4
Vent Location	F 9 3/8	9 3/8	9 3/8	9 3/8	9 3/8	10 1/2	10 1/2
Inlet Location	G 2 3/4	2 3/4	2 3/4	3 1/4	3 1/4	4 1/4	4 1/4

Dimensions in inches

TYPE	LCCR 25	LCCR 50	LCCR 75	LCCR 100	LCCR 125	LCCR 150	LCCR 200
Pipe Size	A 1/4*	1/2	3/4	1	1 1/4	1 1/2	2
Diameter	B 2 1/4	2 1/4	2 1/4	3 1/4	3 1/4	5	5
Length	C 19 1/2	19 1/2	19 1/2	24	24	25 5/8	25 5/8
Vent Size	D 1/4	1/4	1/4	1/4	1/4	1/4	1/4
Drain Size	E 1/4	1/2	1/2	3/4	3/4	3/4	3/4
Vent Location	F 8 3/4	8 3/4	8 3/4	9 7/8	9 7/8	11 1/2	11 1/2
Inlet Location	G 2 3/4	2 3/4	2 3/4	3 1/4	3 1/4	4 1/2	4 1/2
Outlet Location	H 10 7/16	10 7/16	10 7/16	12 11/16	12 11/16	15	15

\*Outlet Conn. 1/4" Male

## Purifier Selection Chart for Air Gas and Steam Applications

AIR AND GAS APPLICATIONS									
This table gives the recommended sizes of Purifiers for best efficiency at various air and gas flows for different pressures.									
FLOW IN C.F.M. (Free Air)									
Type No.	Pipe Size	Pressure in Lbs. Per Square Inch Gauge							
		10	25	50	75	100	150	250	400
25	1/4"	7.5	11.0	14.5	18.4	21.5	28.0	37	51
50	1/2"	23	32	45	55	65	85	115	160
75	3/4"	40	57	80	100	115	150	200	275
100	1"	60	83	115	145	170	220	295	400
125	1 1/4"	90	139	180	220	260	340	450	615
150	1 1/2"	135	185	260	330	385	490	650	900
200	2"	240	330	470	590	700	900	1200	1600

STEAM APPLICATIONS							
This table gives the recommended sizes of Purifiers for best efficiency at various flows for different pressures.							
STEAM FLOW IN LBS. PER HOUR							
Type No.	Pipe Size	Pressure in Lbs. Per Square Inch Gauge					
		10	50	100	150	200	300
50	1/2"	55	105	160	210	250	330
75	3/4"	93	190	280	360	430	590
100	1"	145	285	420	540	660	860
125	1 1/4"	215	430	660	840	1000	1350
150	1 1/2"	310	630	950	1250	1500	1980
200	2"	565	1100	1660	2150	2600	3450

Type LCR & LCCR Separators provide liquid storage for periodic blow down for light entrainment conditions.

All LC Type Separators must be installed in a vertical position with the flow from top to bottom for maximum entrainment separator.

All LC stock item separators have carbon steel body with stainless steel internal element.

All LC Type Separators can, on special order, be built and stamped to ASME Code for Unfired Pressure Vessels suitable for use in a wide range of pressure and temperature, and/or are available in all stainless steel construction.

# ANDERSON SEPARATOR

## Line Type L, LS and LUS Separators

All Anderson Line Separators are designed to eliminate all liquid entrainment of 8-10 microns or larger from air, gas, steam and vapor pipelines without causing any significant pressure drop.

Line Type Separators operate on a patented two stage principle of separation that employs carefully controlled flow guiding the entrainment laden vapor through a series of vanes and baffles. Each component of the separating element is designed to obtain maximum separating efficiency. Briefly, in the first stage of the separation, impingement against a baffle removes

the larger droplets of entrainment.

In the second stage of separation, the separator removes the fine mist entrainment by utilizing centrifugal scrubbing action through a uniquely designed contact element. In each stage, the gas medium and the separated liquid are carefully and continuously guided for maximum efficiency. The separators are designed to handle large volume flow of a broad range of fluids. Self-cleaning and engineered without filters or moving parts, the separators are free from maintenance and repair.

### Type L Separators

Type L Separators from 2½" to 10" pipe sizes are available from stock in both 150 and 300 PSIG ratings.

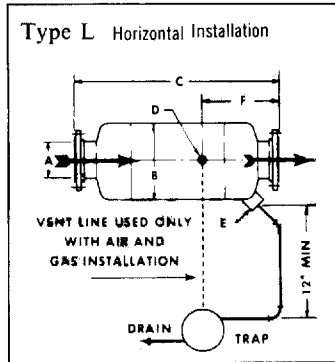
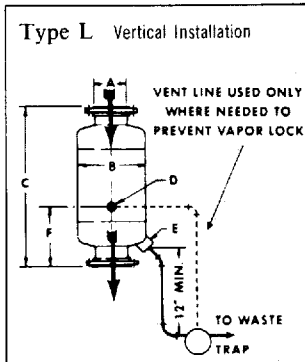

Separators have forged steel flanges, welded steel bodies and stainless steel element blades.

Dimensions in inches

150 and 300 PSIG LINE SEPARATORS							
Type	L-2½	L-3	L-4	L-5	L-6	L-8	L-10
Nominal Pipe Size	A 2½	3	4	5	6	8	10
Diameter	B 6¾	8¾	10¾	12¾	14	16	20
Length	C 19	22	26	30	34	44	52
Vent Size	D ½	½	½	½	½	¾	¾
Drain Size	E 1	1½	1½	2	2	2	2½
Vent Location	F 7%	8%	9¼	10½	12	16	19½
Shipping Weight Lbs.	150# 51	75	110	162	175	272	462
	300# 54	84	140	200	234	412	724

All vessels are designed, built, and stamped to ASME Code for Unfired Pressure Vessels.

### LS & LUS Separator Nozzle Options

#### Type LS Vertical

Arrangement 1

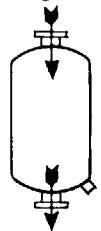

Arrangement 2

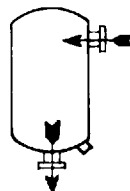

Arrangement 3

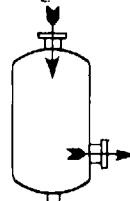

Arrangement 4

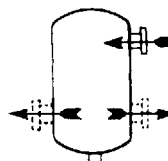

#### Type LS Horizontal

Arrangement 1

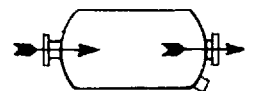

Arrangement 1

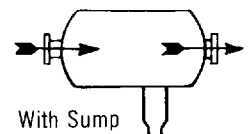

# Line Type LS and LUS Separators

Type LS and LUS Separators are custom designed and built in accordance with Purchaser's flow requirements and material specifications.

All vessels are designed, built, and stamped to ASME Code or Unfired Pressure Vessels.

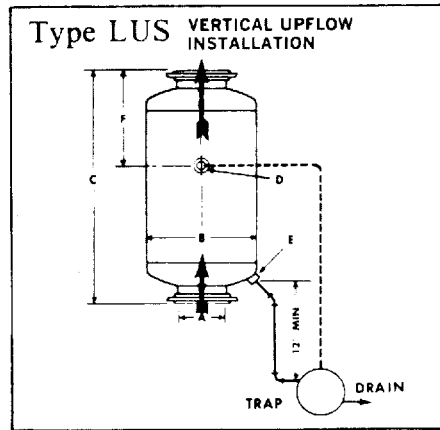
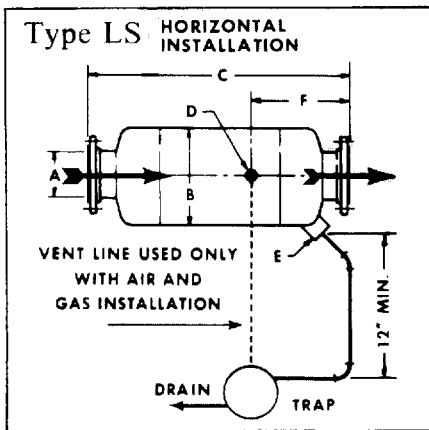
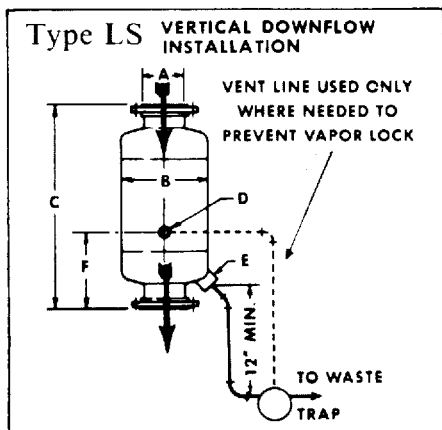

\* Dimensions in inches

Type LS	2½	3	4	5	6	8	10	12	14	16	18	20	22	24	26	28	30	33	36
Nominal Pipe Size .. A	2½	3	4	5	6	8	10	12	14	16	18	20	20	24	24	28	30	30	36
Diameter .....	6½	8½	10¾	12¾	14	16	20	24	24	30	30	36	42	42	48	48	54	60	66
Length .....	19	22	26	30	34	44	52	66	72	78	90	96	108	118	128	136	150	162	174
Vent Size .....	½	½	½	½	½	¾	¾	¾	¾	¾	¾	¾	¾	¾	¾	¾	¾	¾	¾
Drain Size .....	1	1½	1½	2	2	2	2½	2½	2½	2½	3	3	3	4	4	4	4	4	4
Vent Location .....	7¾	8¾	9¼	10½	12	16	19½	23	24	30	34	36	36	42	46	50	53	56	61
Shipping Weight Lbs.	Upon Application																		

\* Dimensions in inches

Type LUS	2½	3	4	5	6	8	10	12	14	16	18	20	22	24	26	28	30	33	36
Nominal Pipe Size .. A	2½	3	4	5	6	8	10	12	14	16	18	20	20	24	24	28	30	30	36
Diameter .....	8¾	10¾	12¾	14	14	16	20	24	24	30	30	36	42	42	48	48	54	60	66
Length .....	20	22	26	30	34	44	52	66	72	78	90	96	114	114	132	138	150	162	174
Vent Size .....	½	½	½	½	½	¾	¾	¾	¾	¾	¾	¾	¾	¾	¾	¾	¾	¾	¾
Drain Size .....	1	1½	1½	2	2	2	2½	2½	2½	2½	3	3	3	4	4	4	4	4	4
Vent Location .....	12	12	16	18	11	12	14	18	20	22	25	27	29	32	34	38	40	43	48
Shipping Weight Lbs.	Upon Application																		

\* Dimensions listed are for 150 PSIG carbon steel vessels and will vary with pressure and materials of construction.

Arrangement 2

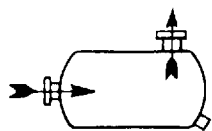

Arrangement 2

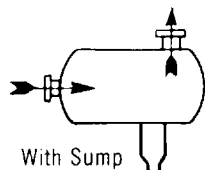

## Type LUS

Arrangement 1

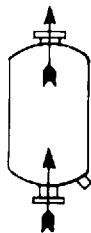

Arrangement 3

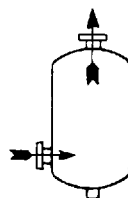

Arrangement 2

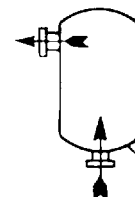

Arrangement 4

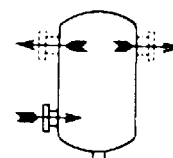

# ANDERSON SEPARATOR

## Receiver-Type LR Separators

Type LR Separators are receiver type separators custom designed and engineered for handling heavy liquid loads and extremely large slugs of entrainment in vapor or gas handling systems. Consisting of an Anderson separator inside a large receiver, the sudden reduction of velocity that occurs once the gas or vapor flow passes the inlet, causes a large percentage of the entrainment to drop to the bottom of the separator. Any entrainment remaining is virtually eliminated by the centrifugal action of the separator inside the receiver.

Three inlet/outlet configurations are available to meet the widest range of installation requirements. Other nozzle arrangements are available upon request. Receiver Type LR Separators are installed in the vertical position only as shown. All vessels are designed, built, and stamped to ASME Code for Unfired Pressure Vessels.

Separators have forged steel flanges and welded steel bodies. All separators are available in alloy steel, monel or other metals.

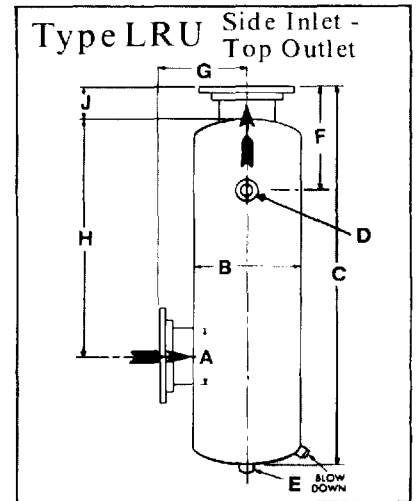
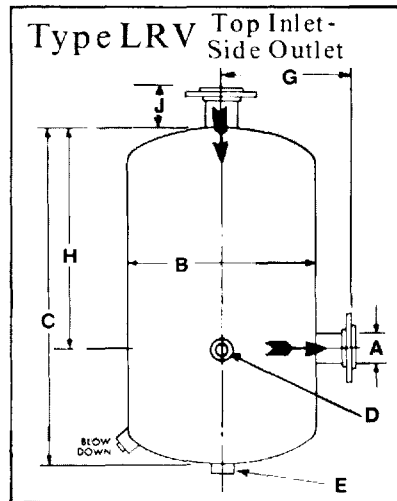
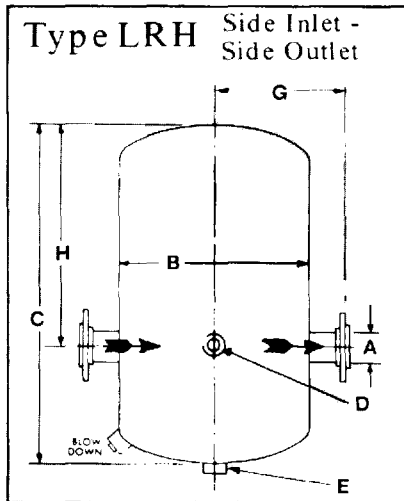

### \* Dimensions in inches

Type LRH and LRV	2½	3	4	5	6	8	10	12	14	16	18	20	24	26	28	30	33	36
Nominal Pipe Size	A 2½	3	4	5	6	8	10	12	14	16	18	20	24	26	28	30	33	36
Min. Diameter	B 8¾	8¾	10¾	12¾	14	18	24	26	30	36	42	42	48	54	60	60	60	66
Min. Length	C 28	31	37	42	48	58	68	80	92	100	112	120	143	156	163	175	203	208
Vent Size	D 1/2	1/2	1/2	1/2	1/2	3/4	3/4	3/4	3/4	3/4	3/4	3/4	3/4	3/4	3/4	3/4	3/4	3/4
Drain Size	E 1½	1½	1½	2	2	2	2½	2½	2½	2½	3	3	4	4	4	4	4	4
	G 9	9	10	11	13	15	18	19	21	25	29	29	33	39	42	43	46	50
	H 15	17	21	25	30	39	46	57	67	73	81	88	108	118	125	136	147	160
	J 5	5	5	5	6	6	6	6	6	7	7	7	8	10	11	11	12	13

### \* Dimensions in inches

Type LRU	2½	3	4	5	6	8	10	12	14	16	18	20	24	26	28	30	33	36
Nominal Pipe Size	A 2½	3	4	5	6	8	10	12	14	16	18	20	24	26	28	30	33	36
Min. Diameter	B 8¾	10¾	12¾	12¾	14	16	20	24	24	30	30	36	42	48	48	54	60	66
Min. Length	C 34	35	40	44	47	55	65	78	91	100	111	119	144	155	166	181	193	212
Vent Size	D 1/2	1/2	1/2	1/2	1/2	3/4	3/4	3/4	3/4	3/4	3/4	3/4	3/4	3/4	3/4	3/4	3/4	3/4
Drain Size	E 1½	1½	1½	2	2	2	2½	2½	2½	2½	3	3	4	4	4	4	4	4
Vent Location	F 10	12	16	18	11	12	14	18	20	22	25	27	32	34	38	40	43	48
	G 9	9	11	12	13	14	16	18	18	21	22	25	29	34	35	38	42	46
	H 20	21	26	29	32	39	45	54	63	68	75	79	96	104	110	121	129	140
	J 4	4	4	4	6	6	6	6	6	6	7	7	7	7	8	8	8	9

\* Dimensions listed are for 150 PSIG carbon steel vessels and will vary with pressure and materials of construction

# ANDERSON SEPARATOR

## Vane-Type Separators

Anderson vane separators contain corrugated profile blades within a large receiver. This separator is built specifically for linear flow applications removing virtually all entrainment of 8 - 10 micron size or larger from the vapor or gas line. Entrainment laden flow is directed into the blades where it is split into individual vertical streams. A series of short radius turns within close proximity utilize inertial forces to trap heavier liquid droplets. Collecting as a film on the profile blades, the liquid flows along the blade and into phase collecting pockets where it deposits into a collecting sump. Because of its special design, Anderson vane separators can handle a large volume of liquid laden flow without re-entrainment. Additionally, the low drag coefficient of the profile design permits the handling of high velocities without excessive pressure loss.

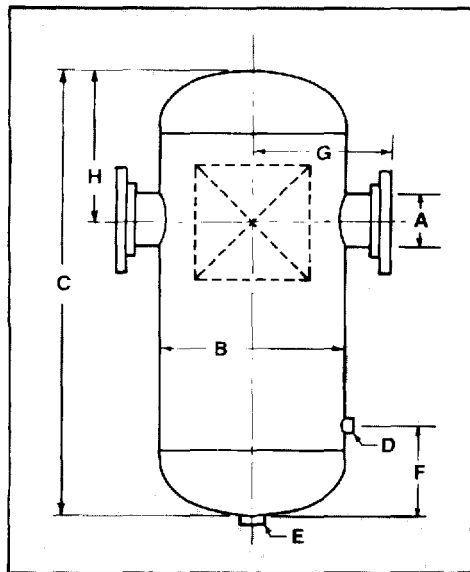

\* Dimensions in inches

Vane Type	2	3	4	6	8	10	12	14	16	18	20	22	24
Nominal Pipe Size A	2	3	4	6	8	10	12	14	16	18	20	22	24
Diameter B	8 $\frac{3}{4}$	10 $\frac{3}{4}$	12 $\frac{3}{4}$	14	16	18	20	24	24	36	36	42	42
Length C	24	26	32	36	42	47	53	55	61	67	73	82	82
Vent Size D	1/2	1/2	1/2	1/2	3/4	3/4	3/4	3/4	3/4	3/4	3/4	3/4	3/4
Drain Size E	1	1 $\frac{1}{2}$	1 $\frac{1}{2}$	2	2	2	2	2	2	3	3	3	3
Vent Location F	6	7	8	8	8	9	9	10	10	13	13	15	15
G	9	10	12	13	14	15	16	18	19	25	25	30	30
H	11	12	15	16	18	23	24	25	28	31	34	39	39

\* Dimensions listed are for 150 PSIG carbon steel vessels and will vary with pressure and materials of construction.

Separators have forged steel flanges and welded steel bodies. All separators are available in alloy steel, monel or other metals.

All vessels are designed, built, and stamped to ASME Code for Unfired Pressure Vessels.

### Optional Base Supports for all Vertical Separators

In order to satisfy as wide a range of installation needs as possible, Anderson Separator models are available in three types of base support arrangements. Anderson

separators also come with many other options such as sight glass and a selection of control connections. For complete details contact the factory.

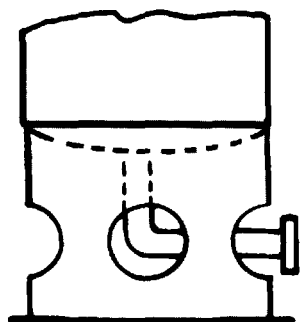

“Skirt” and  
Base Ring Supports

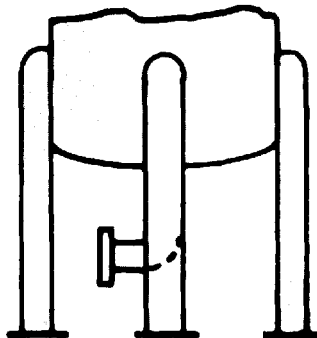

“Leg” Supports

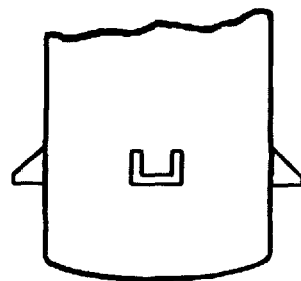

“Lug” Supports

# ANDERSON SEPARATOR

## Coalescer Type C Separators

Type C Horizontal Line Separators are capable of removing finely divided liquid particles (3 microns and larger) suspended in industrial and natural gas lines. The entrainment laden gas enters the separator through a unique coalescer element where the finely divided liquid particles agglomerate. Then the gas flow impinges against a baffle where the larger droplets of entrainment are removed. The remaining fine mist entrain-

ment is then removed by the centrifugal scrubbing action of the separator element. The gas, free of entrainment, passes through the outlet and the separated liquid is carefully directed to the drains. Receiver Tank design is available upon request. The vessels can be furnished with hinged closure or a blind flange and davit arm assembly.

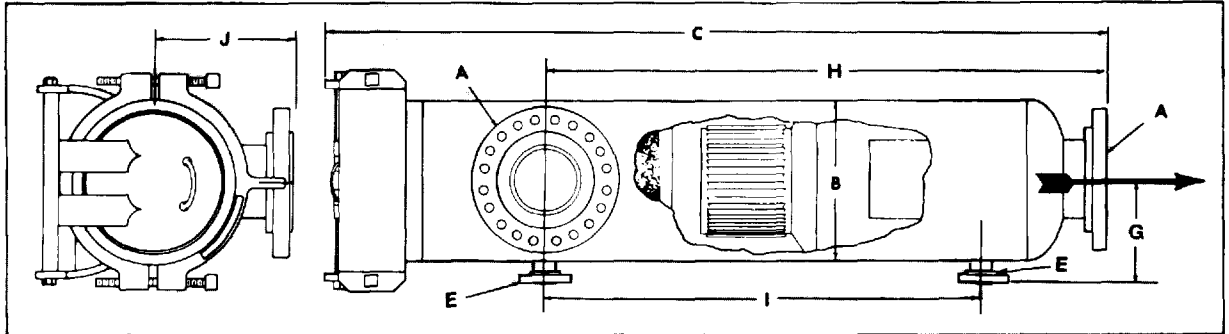

\* Dimensions in inches

Type C		2½	3	4	5	6	8	10	12	14	16	18	20	22	24
Nominal Pipe Size	A	2½	3	4	5	6	8	10	12	14	16	18	20	22	24
Diameter	B	6¾	8¾	10¾	12¾	14	16	20	24	24	30	30	36	42	42
Length	C	39	43	50	54	65	78	90	106	118	132	144	153	182	182
Drain Size	E	2	2	2½	2½	3	3	3	3	3	3	3	3	3	3
	G	6	7	8	9	10	12	14	15	16	18	20	22	25	25
	H	25	29	33	38	44	54	64	77	88	98	108	116	139	139
	I	19	21	23	28	33	41	50	60	71	80	84	97	117	117
	J	7	8	10	11	14	15	18	20	21	24	24	28	32	32

\* Dimensions listed are for 150 PSIG carbon steel vessels and will vary with pressure and materials of construction.

# ANDERSON™ SEPARATOR COMPANY

A Division Of The Clark•Reliance Corporation

16633 FOLTZ INDUSTRIAL PARKWAY ■ STRONGSVILLE, OHIO 44136, U.S.A.  
PHONE: (440) 572-1500 ■ FAX: (440) 238-8828 ■ WWW.CLARK-RELIANCE.COM

A S M E CODE STAMPS

