

BILL OF MATERIAL (CS BODY/416SS TRIM)					BILL OF MATERIAL (316SS BODY/316SS TRIM)					BILL OF MATERIAL (ALL 316SS)							
NO.	NAME OF PART	QTY.	MATERIAL	PART NO.	SPECIFICATION	NO.	NAME OF PART	QTY.	MATERIAL	PART NO.	SPECIFICATION	NO.	NAME OF PART	QTY.	MATERIAL	PART NO.	SPECIFICATION
1	BODY, VALVE	1	CARBON STEEL	PER ORDER	A105	1	BODY, VALVE	1	316/316LSS	PER ORDER	A182 GR.F316/316L	1	BODY, VALVE	1	316/316LSS	PER ORDER	A182 GR.F316/316L
2	SEAT	1	416SS	P125 U3	QQ-S-763	2	SEAT	1	316/316LSS	P125 T2	A479	2	SEAT	1	316/316LSS	P125 T2	A479
3	STEM	1	416SS	S10796 U3		3	STEM	1	316/316LSS	S10796 T2	A276 OR A479	3	STEM	1	316/316LSS	S10796 T2	A276 OR A479
4	YOKE	1	CARBON STEEL	L2073 A5	A105	4	YOKE	1	CARBON STEEL	L2073 A5	A105	4	YOKE, STANDARD	1	316LSS	L2073 TL1	A182 GR.F316L
5	SLEEVE	1	LOW TEMP CS	V10124 A32	A350 GR.LF2	5	SLEEVE	1	316/316LSS	V10124 TL2	A479	5	SLEEVE, 70L YOKE	1	316/316LSS	V10124 TL2	A479
6	SPIRAL GASKET	1	316/FLEXICARB	P5643 T		6	SPIRAL GASKET	1	316/FLEXICARB	P5643 T		6	SPIRAL GASKET	1	316/FLEXICARB	P5643 T	
7	CAP SCREW	4	ALLOY STEEL	P4393 B71	A193 GR.B7	7	CAP SCREW	4	ALLOY STEEL	P4393 B71	A193 GR.B7	7	CAP SCREW	4	316SS	P4393 B8M	A193 GR.B8M
8	WASHER	4	316SS	X174282		8	WASHER	4	316SS	X174282		8	WASHER	4	316SS	X174282	
9	PACKING	1	GRAPHITE/INCONEL	G290		9	PACKING	1	GRAPHITE/INCONEL	G290		9	PACKING	1	GRAPHITE/INCONEL	G290	
10	GLAND	1	CARBON STEEL	V9974 A6	A108	10	GLAND	1	CARBON STEEL	V9974 A6	A108	10	GLAND	1	316SS	V9974 T2	A479
11	GLAND FLANGE	1	CARBON STEEL	V18114 A6		11	GLAND FLANGE	1	CARBON STEEL	V18114 A6		11	GLAND FLANGE	1	316LSS	V18114 TL2	
12	CAP SCREW	2	ALLOY STEEL	X172195	A193 GR.B7	12	CAP SCREW	2	ALLOY STEEL	X172195	A193 GR.B7	12	CAP SCREW	2	316SS	X172198	A193 GR.B8M
13	BALL CHECK	1	440SS	P1 I		13	BALL CHECK	1	316SS	P1 T2	QQ-S-763	13	BALL CHECK	1	316SS	P1 T2	QQ-S-763
14	HANDWHEEL ASSEMBLY	1	CARBON STEEL/303SS	S11717		14	HANDWHEEL ASSEMBLY	1	CARBON STEEL/303SS	S11717		14	HANDWHEEL	1	316SS	PD325 T11	
15	-----	-	-----	-----		15	-----	-	-----	-----		15	SLEEVE, HANDWHEEL	1	316LSS	V11199 TL4	A479
16	NUT, STEM	1	CARBON STEEL	V9822 A		16	NUT, STEM	1	CARBON STEEL	V9822 A		16	NUT, STEM	1	316SS	V9822 B8M	A194 GR.8M
17	TAILPIECE, GAGE CONN.	1	LOW TEMP CS	PER ORDER	A350 GR.LF2	17	TAILPIECE, GAGE CONN.	1	316/316LSS*	P198 T2		17	TAILPIECE, GAGE CONN.	1	316/316LSS*	PER ORDER	
18	NUT, TAILPIECE	1	LOW TEMP CS	PER ORDER	A350 GR.LF2	18	NUT, TAILPIECE	1	LOW TEMP CS	P70 6 A32	A350-LF2	18	NUT, TAILPIECE	1	316/316LSS	PER ORDER	A276 GR.F316/F316L
19	RATING TAG	1	304SS	V22038 1		19	RATING TAG	1	304SS	V22038 1		19	RATING TAG	1	304SS	V22038 1	

*17-4PHSS FOR SPHERICAL TAILPIECES

*17-4PHSS FOR SPHERICAL TAILPIECES

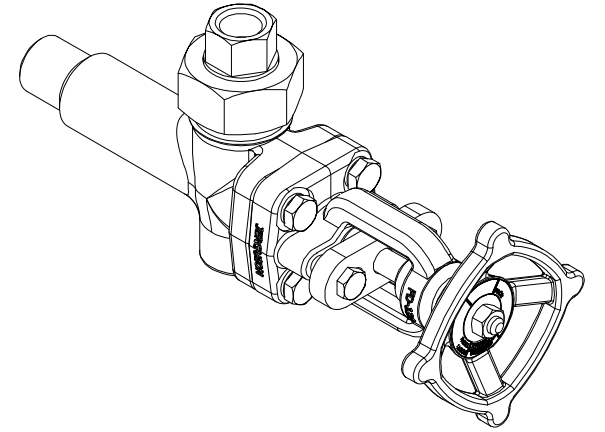

NOTES:

- DIMENSIONS IN INCHES W/ mm EQUIVALENTS IN BRACKETS
- TOP AND BOTTOM VALVES INTERCHANGEABLE
- VALVE RATING - CARBON STEEL:
3000 PSI @ 100°F, 1062 PSI @ 800°F
(211 KG/CM² @ 38°C, 75 KG/CM² @ 427°C)
- VALVE RATING - 316SS:
2100 PSI @ 100°F, 754 PSI @ 800°F
(148 KG/CM² @ 38°C, 53 KG/CM² @ 427°C)
- STEAM RATING = 750 WSP MAX.
- CERTIFIED TO LOW EMISSIONS STANDARD API 624 W/ PACKING G290
- FOR INSTRUMENT USE, "74XL" VALVE IS SUPPLIED W/O BALL CHECK & PUSHER PIN @ END OF STEM
- SEE TABLES FOR AVAILABLE STANDARD CONNECTIONS
- REFER TO THE FOLLOWING (FOR):
 - CATALOG BULLETIN J100.52 (ADDITIONAL INFORMATION)
 - IOM BULLETIN J500.08 (INSTRUCTIONS)
- VALVE "TRIM" = SEAT, STEM & BALL CHECK
- CONSULT FACTORY FOR ALTERNATE MATERIAL OPTIONS

TANK CONNECTION				
1/2" MNPT (OR MSW)	1/2" FNPT (OR FSW)	3/4" MNPT (OR MSW)	3/4" FNPT	1" MNPT (OR MSW)
4.063 [103]	3.188 [81]	4.688 [119]	3.813 [97]	4.500 [114]

UNION GAGE CONNECTION ("B" DIMENSION)							
1/2" MNPT (OR MSW)	1/2" FNPT (OR FSW)	1/2" MNPT SPH. (OR MSW)	1/2" FNPT SPH. (OR FSW)	3/4" MNPT (OR MSW)	3/4" FNPT	3/4" MNPT SPH. (OR MSW)	1" MNPT (OR MSW)
4.063 [103]	3.188 [81]	4.688 [119]	3.813 [97]	4.063 [103]	3.188 [81]	4.688 [119]	4.500 [114]

VENT / DRAIN CONNECTION
1/2" FNPT (OR FSW) ONLY

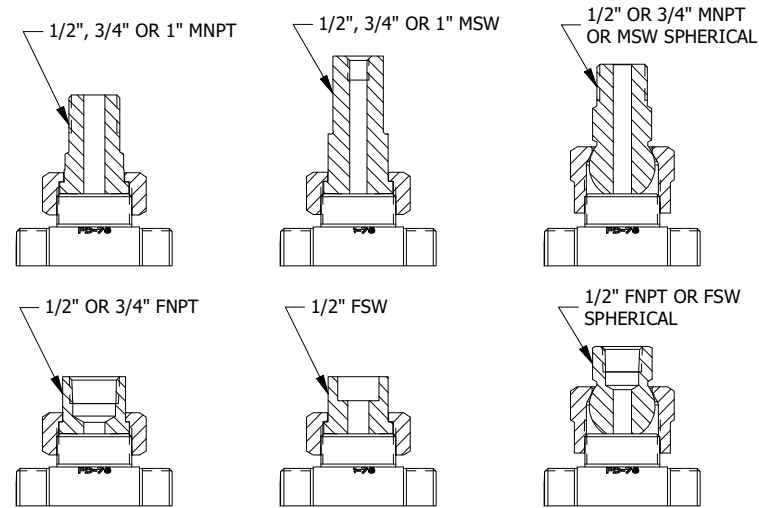

NON-UNION TANK CONNECTION (SEE TABLE)

PUSHER PIN (SEE NOTE 5)

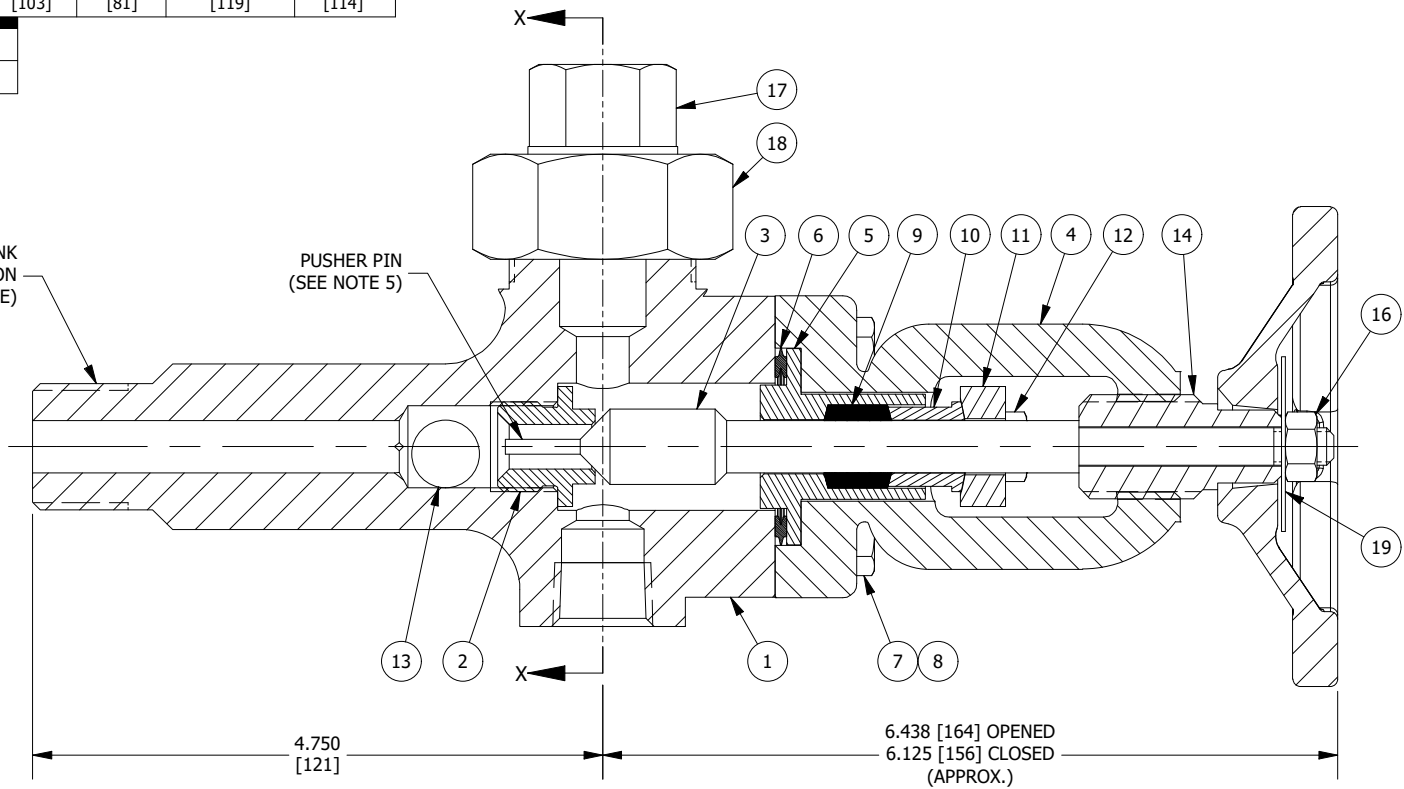

UNION GAGE CONNECTION (SEE TABLE)

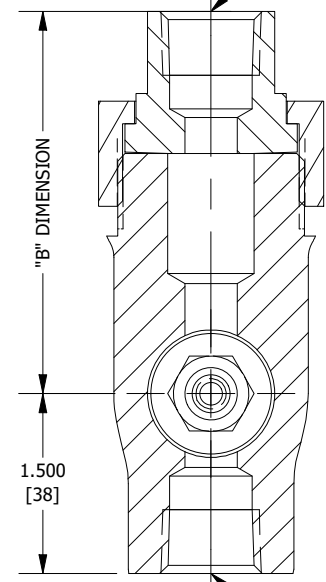

DRAIN CONNECTION (SEE TABLE)

SECTION X-X

GAGE CONNECTION
(3/4" FSW UNION CONNECTION NOT AVAILABLE AS STANDARD)

REV	DATE	REVISION	BY
4	06/08/2022	UPDATED GLAND FLANGE TO V18114 & UPDATED ALL 316SS HANDWHEEL	CMN
3	10/25/2019	CHANGED PACKING MATERIAL FROM GRAPHITE/NICR	JJK
2	2/21/2018	UPDATE BOM, ADDED NOTE 4	JLI
1	12/22/2016	UDATED PACKING G290	DCD

MANUFACTURED BY

 16633 FOLTZ PARKWAY
 STRONGSVILLE, OH 44149 USA
 (440) 572-1500 | www.clarkreliance.com
 © Clark-Reliance® LLC. All Rights Reserved.

#74BL IN-LINE VALVE (PLAIN-CLOSING)
 NON-UNION TANK CONNECTION
 UNION GAGE CONNECTION

JERGUSON®

DRAWN: DD	CHECKED: MK	DATE: 07/08/2013	DRAWING NO.: 74BL	REV.: 4
CDC: 4 : 22-229 : CMN : 06/08/2022			TOLERANCES (U.O.N.): 3 Decimal Places: ± .008" 2 Decimal Places: ± .015" Fractions: ± .025"	
MATERIAL: CS OR 316/316LSS			Machined Holes: ± .005" Angles: ± 1° Finish Marks: ≤ 125 RMS (See PES-004 for details.)	
PART NUMBER: 74BL-(PER ORDER)				

THIS DRAWING CONTAINS MATERIAL THAT IS CONFIDENTIAL AND/OR PRIVILEGED FOR THE SOLE USE OF THE INTENDED RECIPIENT. ANY REVIEW, RELIANCE OR DISTRIBUTION BY OTHERS OR FORWARDING WITHOUT EXPRESS PERMISSION IS STRICTLY PROHIBITED.