

BILL OF MATERIAL (CS BODY/416SS TRIM)					BILL OF MATERIAL (316SS BODY/316SS TRIM)				
NO.	NAME OF PART	QTY.	MATERIAL	PART NO. SPECIFICATION	NO.	NAME OF PART	QTY.	MATERIAL	PART NO. SPECIFICATION
1	BODY, VALVE	1	CARBON STEEL	PER ORDER A105	1	BODY, VALVE	1	316/316LSS	PER ORDER A182 GR.F316/316L
2	SEAT	1	416SS	V9806 U3 QQ-S-763	2	SEAT	1	316/316LSS	V9806 T2
3	SEAT GASKET	1	316SS	P8378 T	3	SEAT GASKET	1	316SS	P8378 T
4	STEM, LOOSE KNOB	1	416SS/STELLITE	S10328 3 U	4	STEM, LOOSE KNOB	1	316SS/STELLITE	S10348 3 T
5	YOKE	1	CARBON STEEL	L707 B A105	5	YOKE	1	CARBON STEEL	L316 B A105
6	-----	-	-----	-----	6	SLEEVE	1	316/316LSS	V9830 TL2 A479
7	SPIRAL GASKET	1	316/FLEXICARB	P5643 T	7	SPIRAL GASKET	1	316/FLEXICARB	P5643 T
8	CAP SCREW	4	ALLOY STEEL	P6475 B71 A193 GR.B7	8	CAP SCREW	4	ALLOY STEEL	P6475 B71 A193 GR.B7
9	PACKING	1	GRAFOIL	G266	9	PACKING	1	GRAFOIL	G266
10	PACKING GLAND	1	CARBON STEEL	V18257 9 AL4 A36	10	PACKING GLAND	1	CARBON STEEL	V18257 9 AL4 A36
11	CAP SCREW	2	ALLOY STEEL	P5729 B71 A193 GR.B7	11	CAP SCREW	2	ALLOY STEEL	P5729 B71 A193 GR.B7
12	BUSHING	1	ALUMINUM BRONZE	P8375 F32 QQ-C-465-B	12	BUSHING	1	ALUMINUM BRONZE	P8375 F32 QQ-C-465-B
13	NUT, BUSHING	1	CARBON STEEL	P5665 A6 A108	13	NUT, BUSHING	1	CARBON STEEL	P5665 A6 A108
14	HANDWHEEL	1	ALUMINUM	V9808 E B26	14	HANDWHEEL	1	ALUMINUM	V9808 E B26
15	NUT, STEM	1	CARBON STEEL	V9822 A	15	NUT, STEM	1	CARBON STEEL	V9822 A
16	BALL CHECK	1	440SS	P1 I	16	BALL CHECK	1	316SS	P1 T2 QQ-S-763
17	TAILPIECE, GAGE CONN.	1	LOW TEMP CS	PER ORDER A108	17	TAILPIECE, GAGE CONN.	1	316/316LSS	PER ORDER
18	NUT, TAILPIECE	1	LOW TEMP CS	PER ORDER A350 GR.LF2	18	NUT, TAILPIECE	1	LOW TEMP CS	PER ORDER A350 GR.LF2
19	GASKET, TAILPIECE	1	GRAPHITE/304SS	V9864 1	19	GASKET, TAILPIECE	1	GRAPHITE/304SS	V9864 1
20	RATING TAG	1	304SS	V22038 1	20	RATING TAG	1	304SS	V22038 1

- NOTES:
- DIMENSIONS IN INCHES W/ mm EQUIVALENTS IN BRACKETS
  - TOP AND BOTTOM VALVES INTERCHANGEABLE (I.E., MIRROR IMAGES) (BOTTOM VALVE SHOWN)
  - VALVE RATING - CARBON STEEL:  
6000 PSI @ 100°F, 3362 PSI @ 800°F  
(422 KG/CM<sup>2</sup> @ 38°C, 236 KG/CM<sup>2</sup> @ 427°C)  
VALVE RATING - 316SS:  
6000 PSI @ 100°F, 3760 PSI @ 800°F  
(422 KG/CM<sup>2</sup> @ 38°C, 264 KG/CM<sup>2</sup> @ 427°C)
  - BALL CHECK OPTIONAL - FURNISHED ON REQUEST  
NOTE: WHEN HORIZONTAL BALL CHECK IS REQUESTED, 3-PIECE LOOSE KNOB STEM IS REPLACED BY 1-PIECE STELLITED STEM S10667 U (416SS) OR S10667 T (316SS) AND SEAT V10273 U3 (416SS) OR V10273 T2 (316SS)
  - SEE TABLES FOR AVAILABLE STANDARD CONNECTIONS
  - REFER TO THE FOLLOWING (FOR):  
• CATALOG BULLETIN J100.57 (ADDITIONAL INFORMATION)  
• IOM BULLETIN J500.10 (INSTRUCTIONS)
  - VALVE "TRIM" = SEAT, STEM & (OPTIONAL) BALL CHECK
  - CONSULT FACTORY FOR ALTERNATE MATERIAL OPTIONS (NOT AVAILABLE IN ALL 316SS)

TANK CONNECTION				
1/2" MNPT (OR MSW)	1/2" FNPT (OR FSW)	3/4" MNPT (OR MSW)	3/4" FNPT (OR FSW)	1" MNPT (OR MSW)
UNION GAGE CONNECTION ("B" DIMENSION)				
1/2" MNPT (OR MSW)	1/2" FNPT (OR FSW)	3/4" MNPT (OR MSW)	3/4" FNPT	1" MNPT (OR MSW)
4.438 [113]	3.563 [90]	4.438 [113]	3.563 [90]	4.875 [124]
VENT / DRAIN CONNECTION				
1/2" FNPT (OR FSW) ONLY				

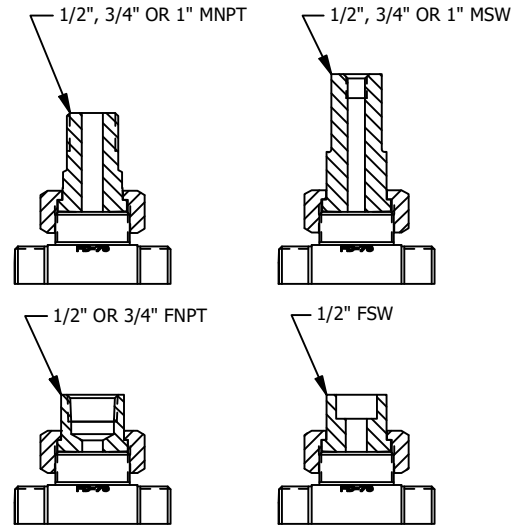

GAGE CONNECTION  
(3/4" FSW UNION CONNECTION NOT AVAILABLE AS STANDARD)

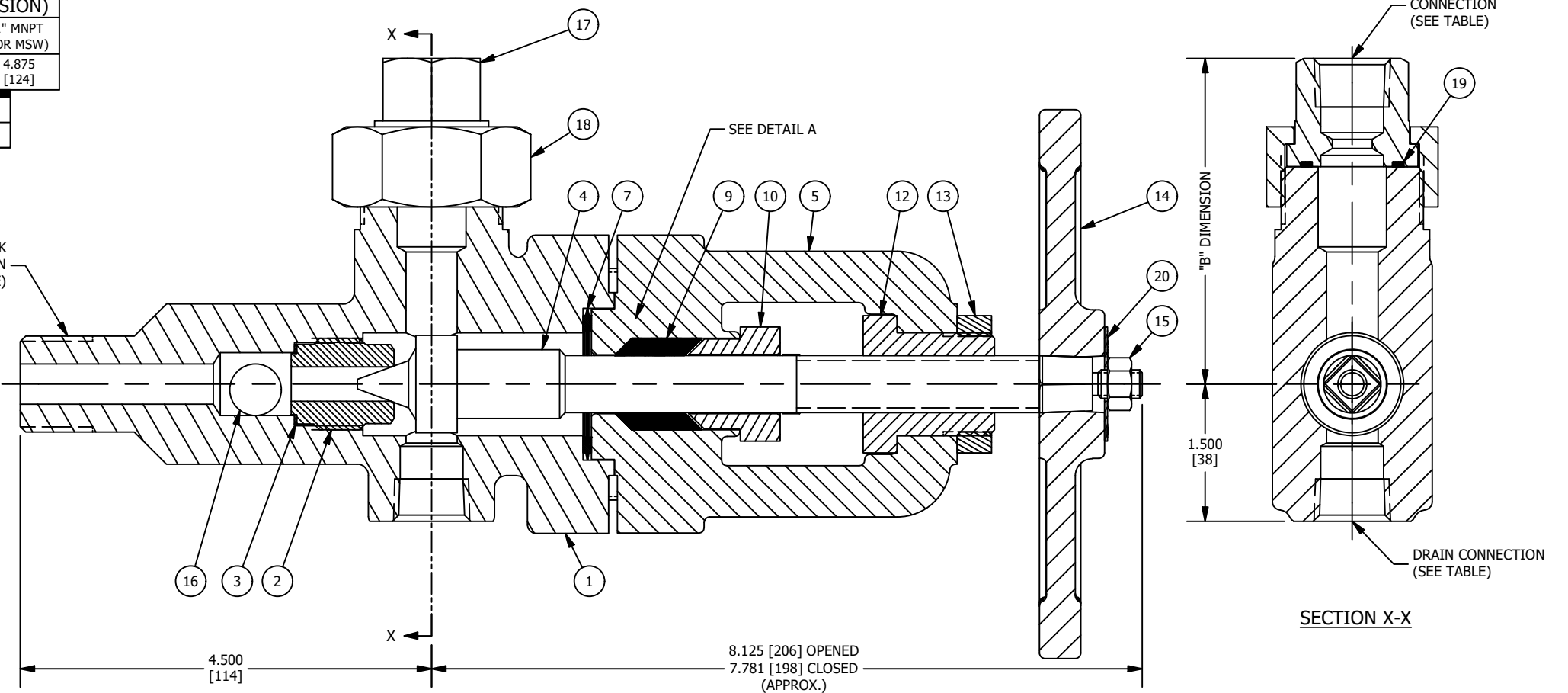
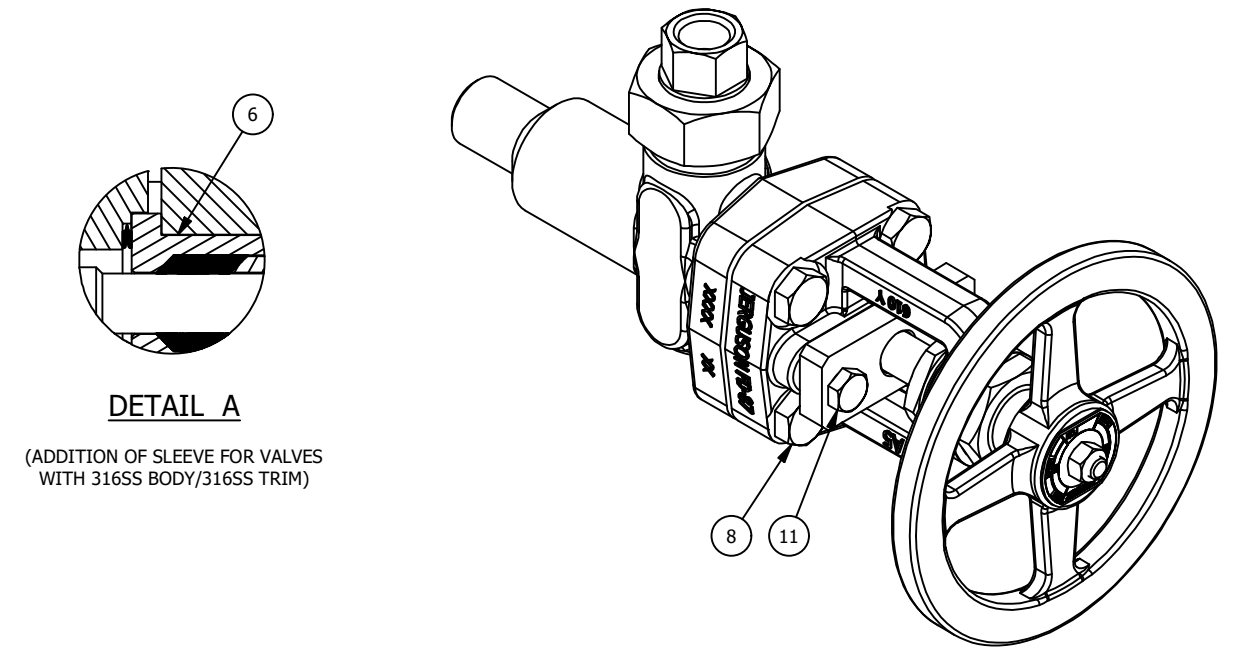

<b>MANUFACTURED BY</b>  16633 FOLTZ PARKWAY STRONGSVILLE, OH 44149 USA (440) 572-1500   www.clarkreliance.com © Clark-Reliance® LLC. All Rights Reserved.	<b>#84H IN-LINE VALVE (PLAIN-CLOSING)</b> <b>NON-UNION TANK CONNECTION</b> <b>UNION GAGE CONNECTION</b>		DRAWN: JLi CHECKED: MK DATE: 04/03/2018 CDC: 1 : 23-122 : CMN : 04/24/2023	DRAWING NO.: <b>84H</b>	REV.: <b>1</b>
	<b>JERGUSON®</b>			MATERIAL: PER ORDER PART NUMBER: <b>84H-(PER ORDER)</b>	<small>TOLERANCES (U.O.M.):          3 Decimal Places: ± .030"          2 Decimal Places: ± .060"          Fractions: ± .030"          Machined Holes: ± .005"          Angles: ± 1°          Finish Marks: ≤ 125 RMS          (See PES-004 for details.)</small>

THIS DRAWING CONTAINS MATERIAL THAT IS CONFIDENTIAL AND/OR PRIVILEGED FOR THE SOLE USE OF THE INTENDED RECIPIENT. ANY REVIEW, RELIANCE OR DISTRIBUTION BY OTHERS OR FORWARDING WITHOUT EXPRESS PERMISSION IS STRICTLY PROHIBITED.