

BILL OF MATERIAL (CS BODY/416SS TRIM)				
NO.	NAME OF PART	QTY.	MATERIAL	SPECIFICATION
1	BODY, VALVE	1	CARBON STEEL	PER ORDER A105
2	SEAT	1	416SS	P125 U3 QQ-S-763
3	STEM	1	416SS	S10796 U3
4	YOKE	1	CARBON STEEL	L2073 A5 A105
5	SLEEVE	1	LOW TEMP CS	V10124 A32 A350 GR.LF2
6	SPIRAL GASKET	1	316/FLEXICARB	P5643 T
7	CAP SCREW	4	ALLOY STEEL	P4393 B71 A193 GR.B7
8	WASHER	4	316SS	X174282
9	PACKING	1	GRAPHITE/INCONEL	G290
10	GLAND	1	CARBON STEEL	V9974 A6 A108
11	GLAND FLANGE	1	CARBON STEEL	V18114 A6
12	CAP SCREW	2	ALLOY STEEL	X172195 A193 GR.B7
13	BALL CHECK	1	440SS	P1 I
14	HANDWHEEL ASSEMBLY	1	CARBON STEEL/303SS	S11717
15	-----	-	-----	-----
16	NUT, STEM	1	CARBON STEEL	V9822 A
17	TAILPIECE, GAGE CONN.	1	LOW TEMP CS	PER ORDER A350 GR.LF2
18	NUT, TAILPIECE	1	LOW TEMP CS	PER ORDER A350 GR.LF2
19	RATING TAG	1	304SS	V22038 1

BILL OF MATERIAL (316SS BODY/316SS TRIM)				
NO.	NAME OF PART	QTY.	MATERIAL	SPECIFICATION
1	BODY, VALVE	1	316/316LSS	PER ORDER A182 GR.F316/316L
2	SEAT	1	316/316LSS	P125 T2 A479
3	STEM	1	316/316LSS	S10796 T2 A276 OR A479
4	YOKE	1	CARBON STEEL	L2073 A5 A105
5	SLEEVE	1	316/316LSS	V10124 TL2 A479
6	SPIRAL GASKET	1	316/FLEXICARB	P5643 T
7	CAP SCREW	4	ALLOY STEEL	P4393 B71 A193 GR.B7
8	WASHER	4	316SS	X174282
9	PACKING	1	GRAPHITE/INCONEL	G290
10	GLAND	1	CARBON STEEL	V9974 A6 A108
11	GLAND FLANGE	1	CARBON STEEL	V18114 A6
12	CAP SCREW	2	ALLOY STEEL	X172195 A193 GR.B7
13	BALL CHECK	1	316SS	P1 T2 QQ-S-763
14	HANDWHEEL ASSEMBLY	1	CARBON STEEL/303SS	S11717
15	-----	-	-----	-----
16	NUT, STEM	1	CARBON STEEL	V9822 A
17	TAILPIECE, GAGE CONN.	1	316/316LSS*	PER ORDER
18	NUT, TAILPIECE	1	LOW TEMP CS	PER ORDER A350 GR.LF2
19	RATING TAG	1	304SS	V22038 1

BILL OF MATERIAL (ALL 316SS)				
NO.	NAME OF PART	QTY.	MATERIAL	SPECIFICATION
1	BODY, VALVE	1	316/316LSS	PER ORDER A182 GR.F316/316L
2	SEAT	1	316/316LSS	P125 T2 A479
3	STEM	1	316/316LSS	S10796 T2 A276 OR A479
4	YOKE	1	316LSS	L2073 TL1 A182 GR.F316/316L
5	SLEEVE	1	316/316LSS	V10124 TL2 A479
6	SPIRAL GASKET	1	316/FLEXICARB	P5643 T
7	CAP SCREW	4	316SS	P4393 B8M A193 GR.B8M
8	WASHER	4	316SS	X174282
9	PACKING	1	GRAPHITE/INCONEL	G290
10	GLAND	1	316SS	V9974 T2 A479
11	GLAND FLANGE	1	316LSS	V18114 TL2
12	CAP SCREW	2	316SS	X172198 A193 GR.B8M
13	BALL CHECK	1	316SS	P1 T2 QQ-S-763
14	HANDWHEEL	1	316SS	PD325 T11
15	SLEEVE, YOKE	1	316LSS	V11199 TL4 A479
16	NUT, STEM	1	316SS	V9822 B8M A194 GR.8M
17	TAILPIECE, 3/4"FNPT	1	316/316LSS*	PER ORDER A276 GR.F316/316L
18	NUT, TAILPIECE	1	316/316LSS	PER ORDER A276 GR.F316/316L
19	RATING TAG	1	304SS	V22038 1

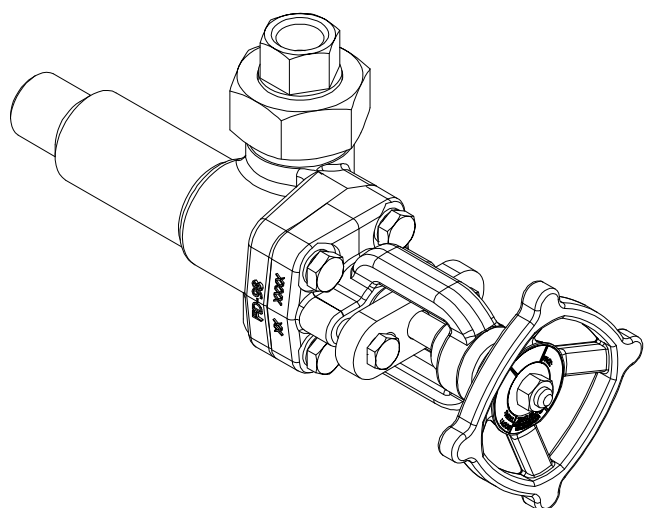

- NOTES:
- DIMENSIONS IN INCHES W/ mm EQUIVALENTS IN BRACKETS
 - TOP AND BOTTOM VALVES SAME EXCEPT OPPOSITE HANDING (I.E., MIRROR IMAGES) (BOTTOM LEFT HAND VALVE SHOWN)
 - VALVE RATING - CARBON STEEL:
3000 PSI @ 100°F, 1062 PSI @ 800°F
(211 KG/CM² @ 38°C, 75 KG/CM² @ 427°C)
 - VALVE RATING - 316SS:
2100 PSI @ 100°F, 754 PSI @ 800°F
(148 KG/CM² @ 38°C, 53 KG/CM² @ 427°C)
 - CERTIFIED TO LOW EMISSIONS STANDARD API 624 W/ PACKING G290
 - FOR INSTRUMENT USE, "77XL" VALVE IS SUPPLIED W/O BALL CHECK & PUSHER PIN @ END OF STEM
 - SEE TABLES FOR AVAILABLE STANDARD CONNECTIONS
 - REFER TO THE FOLLOWING (FOR):
 - CATALOG BULLETIN J100.52 (ADDITIONAL INFORMATION)
 - IOM BULLETIN J500.08 (INSTRUCTIONS)
 - VALVE "TRIM" = SEAT, STEM & BALL CHECK
 - CONSULT FACTORY FOR ALTERNATE MATERIAL OPTIONS

* 17-4PHSS FOR SPHERICAL TAILPIECES

TANK CONNECTION				
1/2" MNPT (OR MSW)	1/2" FNPT (OR FSW)	3/4" MNPT (OR MSW)	3/4" FNPT (OR FSW)	1" MNPT (OR MSW)
4.063 [103]	3.188 [81]	4.688 [119]	3.813 [97]	4.500 [114]

UNION GAGE CONNECTION ("B" DIMENSION)							
1/2" MNPT (OR MSW)	1/2" FNPT (OR FSW)	1/2" MNPT SPH. (OR MSW)	1/2" FNPT SPH. (OR FSW)	3/4" MNPT (OR MSW)	3/4" FNPT (OR MSW)	3/4" MNPT SPH. (OR MSW)	1" MNPT (OR MSW)
4.063 [103]	3.188 [81]	4.688 [119]	3.813 [97]	4.063 [103]	3.188 [81]	4.688 [119]	4.500 [114]

VENT / DRAIN CONNECTION
1/2" OR 3/4" FNPT (OR FSW) ONLY

* 17-4PHSS FOR SPHERICAL TAILPIECES

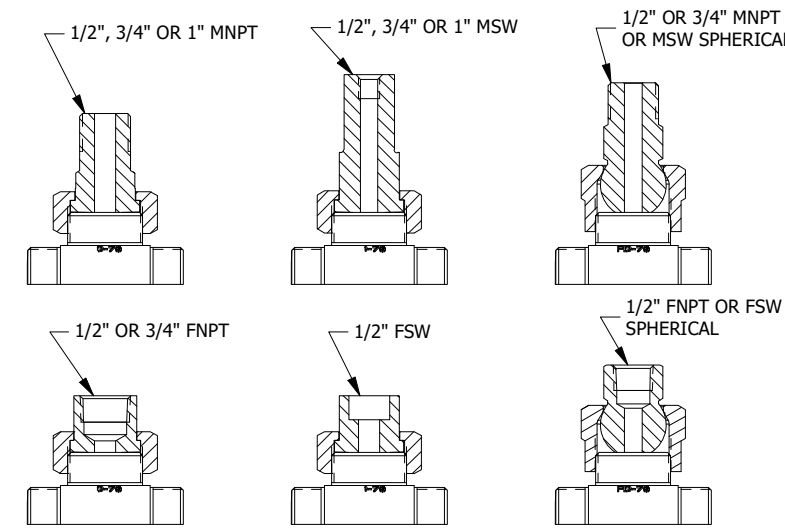

GAGE CONNECTION
(3/4" FSW UNION CONNECTION NOT AVAILABLE AS STANDARD)

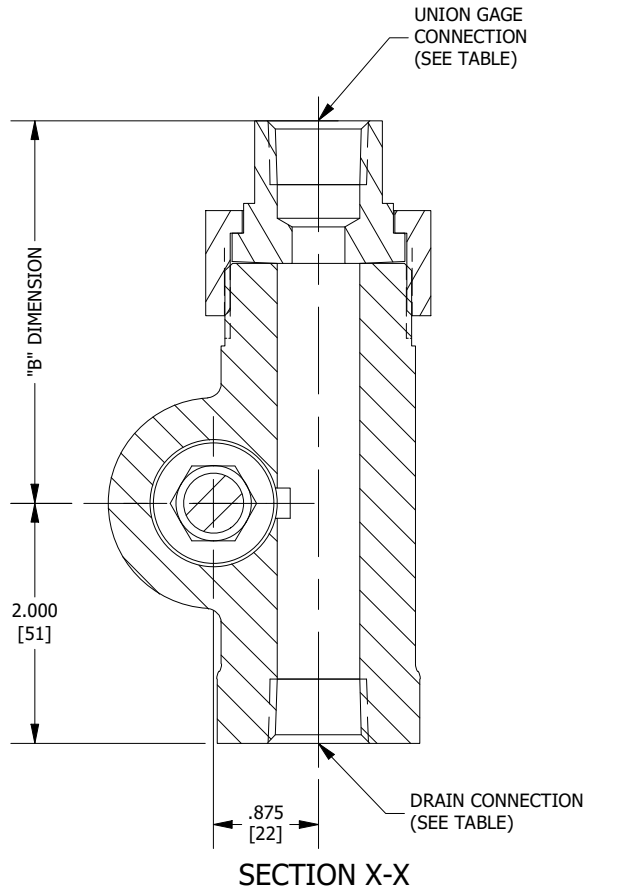
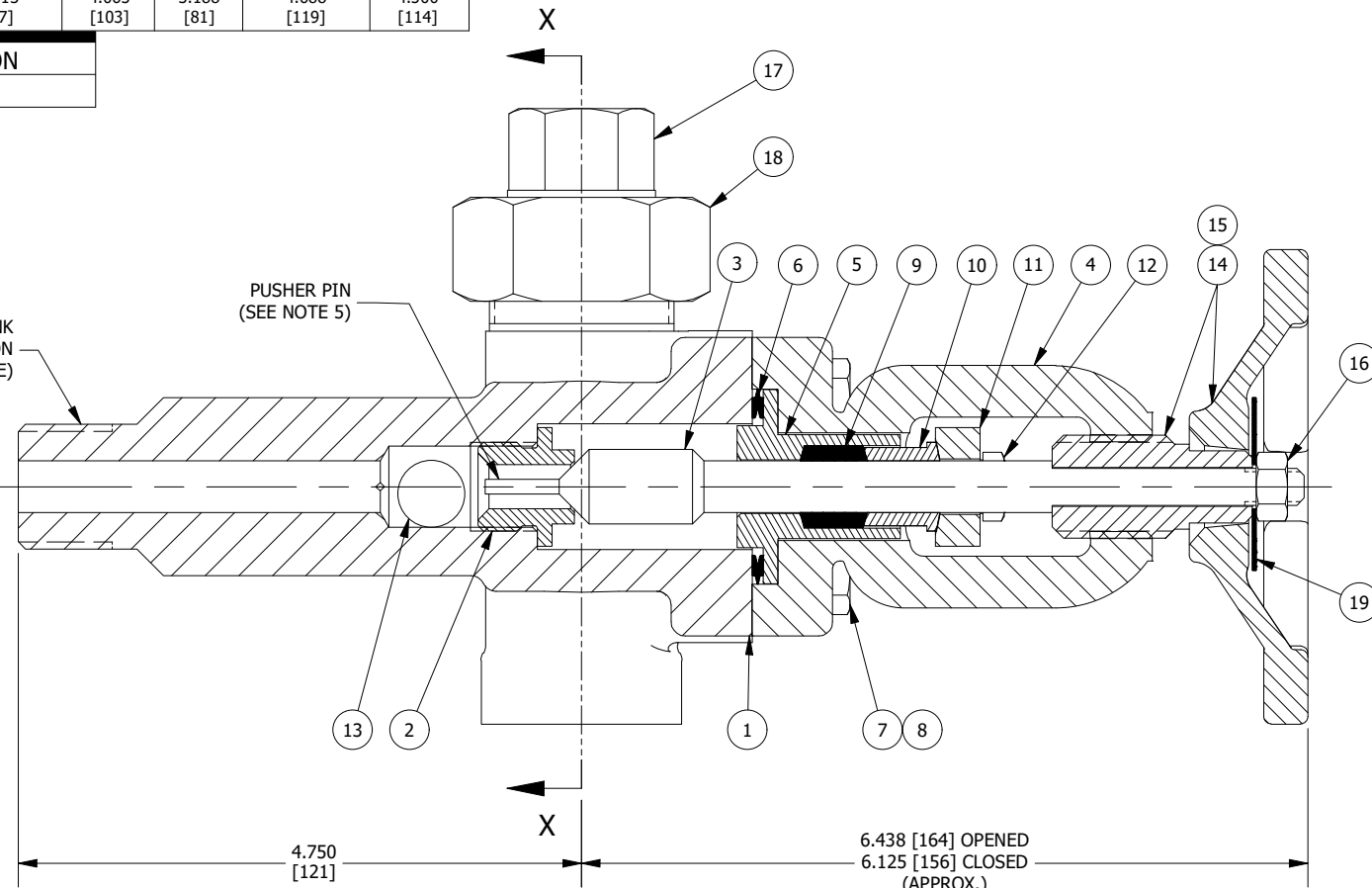

REV	DATE	REVISION	BY
6	06/10/2022	UPDATED GLAND FLANGE TO V18114 & UPDATED ALL 316SS HANDWHEEL	CMN
5	10/25/2019	CHANGED PACKING MATERIAL FROM GRAPHITE/NICR	JJK
4	2/21/2018	UPDATE BOM, ADDED NOTE 4	JLi
3	1/4/2017	CHANGED PACKING FROM G261 TO G290	DCD

MANUFACTURED BY
Clark-Reliance®
 16633 FOLTZ PARKWAY
 STRONGSVILLE, OH 44149 USA
 (440) 572-1500 | www.clarkreliance.com
 © Clark-Reliance® LLC. All Rights Reserved.

#77BL OFFSET VALVE (PLAIN-CLOSING)
 NON-UNION TANK CONNECTION
 UNION GAGE CONNECTION
JERGUSON®

DRAWN: DD	CHECKED: MK	DATE: 03/12/2015	CDC: 6: 22-229: CMN: 06/08/2022	MATERIAL: CS OR 316.316LSS	PART NUMBER: 77BL-(PER ORDER)
DRAWING NO.: 77BL		REV.: 6		TOLERANCES (U.O.N.): 3 Decimal Places: ± .008" 2 Decimal Places: ± .015" Fractions: ± .025" Machined Holes: ± .005" Angles: ± 1° Finish Marks: ≤ 125 RMS (See PES-004 for details.)	

THIS DRAWING CONTAINS MATERIAL THAT IS CONFIDENTIAL AND/OR PRIVILEGED FOR THE SOLE USE OF THE INTENDED RECIPIENT. ANY REVIEW, RELIANCE OR DISTRIBUTION BY OTHERS OR FORWARDING WITHOUT EXPRESS PERMISSION IS STRICTLY PROHIBITED.