

BILL OF MATERIAL (CS BODY/416SS TRIM)					BILL OF MATERIAL (316SS BODY/316SS TRIM)					BILL OF MATERIAL (ALL316SS)							
NO.	NAME OF PART	QTY.	MATERIAL	PART NO.	SPECIFICATION	NO.	NAME OF PART	QTY.	MATERIAL	PART NO.	SPECIFICATION	NO.	NAME OF PART	QTY.	MATERIAL	PART NO.	SPECIFICATION
1	BODY, VALVE	1	CARBON STEEL	PER ORDER	A105	1	BODY, VALVE	1	316/316LSS	PER ORDER	A182 GR.F316/F316L	1	BODY, VALVE	1	316/316LSS	PER ORDER	A182 GR.F316/F316L
2	SEAT	1	416SS	P125 U3	QQ-S-763	2	SEAT	1	316/316LSS	P125 T2	A479	2	SEAT	1	316/316LSS	P125 T2	A479
3	STEM	1	416SS	S121 U3	QQ-S-763	3	STEM	1	316/316LSS	S121 T2	A479	3	STEM	1	316/316LSS	S121 T2	A479
4	TAILPIECE, TANK CONN.	1	LOW TEMP CS	PER ORDER	A350 GR.LF2	4	TAILPIECE, TANK CONN.	1	316/316LSS*	PER ORDER		4	TAILPIECE, TANK CONN.	1	316/316LSS*	PER ORDER	
5	NUT, TAILPIECE	1	LOW TEMP CS	PER ORDER	A350 GR.LF2	5	NUT, TAILPIECE	1	LOW TEMP CS	PER ORDER	A350 GR.LF2	5	NUT, TAILPIECE	1	316/316LSS	PER ORDER	A276 GR.F316/F316L
6	SLEEVE	1	LOW TEMP CS	P182 A32	A350 GR.LF2	6	SLEEVE	1	316/316LSS	P182 T2		6	SLEEVE	1	316/316LSS	P182 T2	
7	NUT, SLEEVE	2	LOW TEMP CS	P70 6 A32	A350 GR.LF2	7	NUT, SLEEVE	2	LOW TEMP CS	P70 6 A32	A350 GR.LF2	7	NUT, SLEEVE	2	316/316LSS	P70 6 T2	A276 GR.F316/F316L
8	PACKING RING	1	LOW TEMP CS	P254 1 A32	A350 GR.LF2	8	PACKING RING	1	316/316LSS	P254 1 T2	A479	8	PACKING RING	1	316/316LSS	P254 1 T2	A479
9	PACKING	4	CARBON YARN/INCONEL	G259		9	PACKING	4	CARBON YARN/INCONEL	G259		9	PACKING	4	CARBON YARN/INCONEL	G259	
10	GLAND	1	LOW TEMP CS	P39 A32	A350 GR.LF2	10	GLAND	1	LOW TEMP CS	P39 A32	A350 GR.LF2	10	GLAND	1	316/316LSS	P39 T2	A479
11	NUT, GLAND	1	LOW TEMP CS	P70 3 A32	A350 GR.LF2	11	NUT, GLAND	1	LOW TEMP CS	P70 3 A32	A350 GR.LF2	11	NUT, GLAND	1	316/316LSS	P70 3 T2	A276 GR.F316/F316L
12	BALL CHECK	1	440SS	P1 I		12	BALL CHECK	1	316SS	P1 T2	QQ-S-763	12	BALL CHECK	1	316SS	P1 T2	QQ-S-763
13	SQUARE HEAD PLUG	2	CARBON STEEL	X 171930		13	SQUARE HEAD PLUG	2	316SS	X172026		13	SQUARE HEAD PLUG	2	316SS	X172026	
14	HANDWHEEL	1	CARBON STEEL	PD325 D1		14	HANDWHEEL	1	CARBON STEEL	PD325 D1		14	HANDWHEEL	1	CARBON STEEL	PD325 D1	
15	NUT, STEM	1	CARBON STEEL	P78 6 A12	A563	15	NUT, STEM	1	CARBON STEEL	P78 6 A12	A563	15	NUT, STEM	1	316SS	P78 6 T	
16	TAILPIECE, GAGE CONN.	1	LOW TEMP CS	PER ORDER	A350 GR.LF2	16	TAILPIECE, GAGE CONN.	1	316/316LSS*	PER ORDER		16	TAILPIECE, GAGE CONN.	1	316/316LSS*	PER ORDER	
17	NUT, TAILPIECE	1	LOW TEMP CS	PER ORDER	A350 GR.LF2	17	NUT, TAILPIECE	1	LOW TEMP CS	PER ORDER	A350 GR.LF2	17	NUT, TAILPIECE	1	316/316LSS	PER ORDER	A276 GR.F316/F316L
18	RATING TAG	1	304SS	V22038 2		18	RATING TAG	1	304SS	V22038 2		18	RATING TAG	1	304SS	V22038 2	

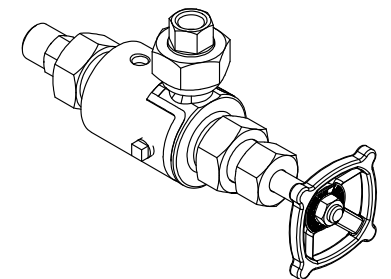

- NOTES:
- DIMENSIONS IN INCHES W/ mm EQUIVALENTS IN BRACKETS
  - TOP AND BOTTOM VALVES INTERCHANGEABLE
  - VALVE RATING - CARBON STEEL & 316SS:  
4000 PSI @ 100°F, 1308 PSI @ 800°F  
(281 KG/CM<sup>2</sup> @ 38°C, 92 KG/CM<sup>2</sup> @ 427°C)  
JACKET RATING - 600# WSP
  - SEE TABLES FOR AVAILABLE STANDARD CONNECTIONS
  - REFER TO THE FOLLOWING (FOR):
    - CATALOG BULLETIN J100.55 (ADDITIONAL INFORMATION)
    - IOM BULLETIN J500.07 (INSTRUCTIONS)
  - VALVE "TRIM" = SEAT, STEM & BALL CHECK
  - CONSULT FACTORY FOR ALTERNATE MATERIAL OPTIONS

\*17-4PHSS FOR SPHERICAL TAILPIECES

\*17-4PHSS FOR SPHERICAL TAILPIECES

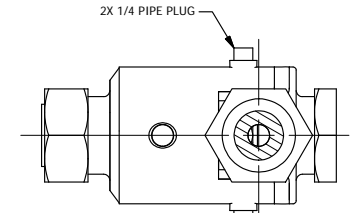

SECTION Y-Y

UNION TANK CONNECTION ("A" DIMENSION)									
1/2" MNPT (OR MSW)	1/2" FNPT (OR FSW)	1/2" MNPT SPH (OR MSW)	1/2" FNPT SPH (OR FSW)	3/4" MNPT	3/4" MSW	3/4" FNPT	3/4" MNPT SPH (OR MSW)	1" MNPT (OR MSW)	
5.953 [151]	5.060 [129]	6.560 [167]	5.685 [144]	5.935 [151]	6.747 [171]	5.060 [129]	6.560 [167]	6.372 [162]	

UNION GAGE CONNECTION ("B" DIMENSION)									
1/2" MNPT (OR MSW)	1/2" FNPT (OR FSW)	1/2" MNPT SPH (OR MSW)	1/2" FNPT SPH (OR FSW)	3/4" MNPT	3/4" MSW	3/4" FNPT	3/4" MNPT SPH (OR MSW)	1" MNPT (OR MSW)	
4.501 [114]	3.626 [92]	5.126 [130]	4.251 [108]	4.501 [114]	4.501 [114]	3.626 [92]	5.126 [130]	4.938 [125]	

VENT / DRAIN CONNECTION	
1/2" FNPT (OR FSW) ONLY	



SECTION X-X

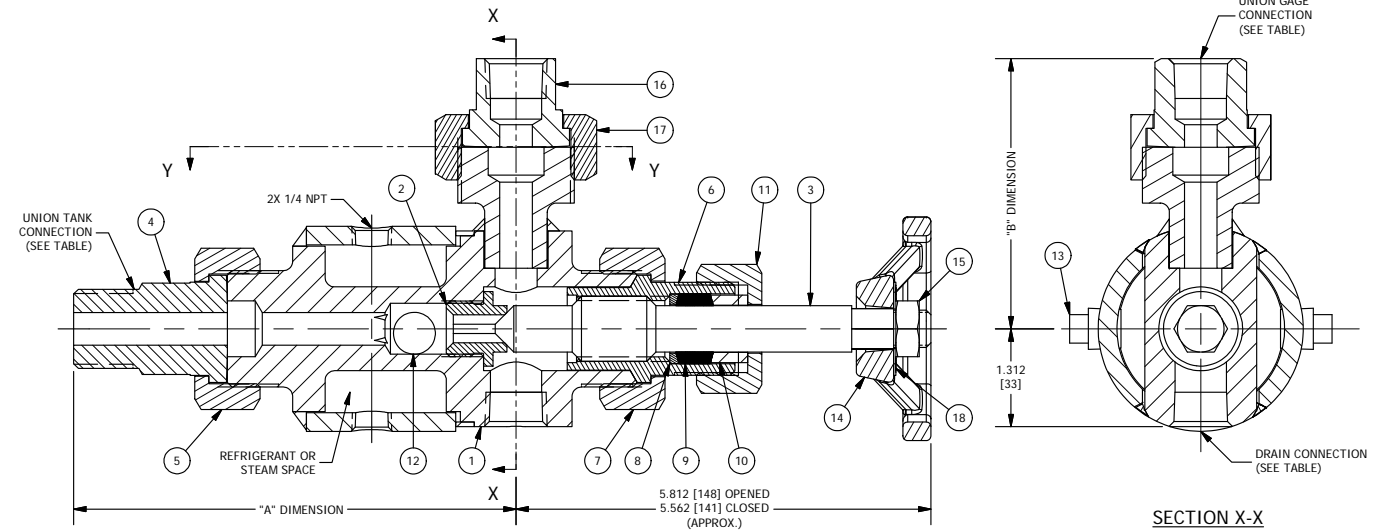

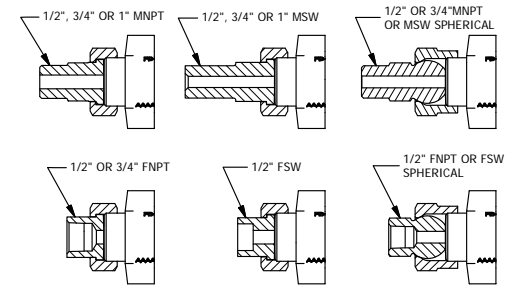
TANK & GAGE CONNECTION

(3/4" FSW UNION CONNECTION NOT AVAILABLE AS STANDARD)

2	10/28/2019	CHANGED PACKING MATERIAL FROM GRAPHITE/NICR	JJK
1	3/7/2018	UPDATE TO 3D, UPDATE BOM	JLI
REV	DATE	REVISION	BY

MANUFACTURED BY  
**Clark-Reliance®**  
 16633 FOLTZ PARKWAY  
 STRONGSVILLE, OH 44149 USA  
 (440) 572-1500 | www.clarkreliance.com  
 © Clark-Reliance® Corporation. All Rights Reserved.

**JERGUSON®**  
 #94 IN-LINE VALVE (PLAIN-CLOSING)  
 UNION TANK & GAGE CONNECTIONS

DRAWN: JLI	REV.: 2
CHECKED: MK	
DATE: 2/6/2018	
REVISION: 2	
DRAWING NO.: 94	