

Repair Instructions for FG Type Probes with RK-33 Repair Kit



Caution: Before proceeding, follow all plant lock out - tag out procedures required. Notify proper personnel that work is being done and make sure to by-pass any alarms and cutout trips. Verify that all power is turned off to the equipment. If under pressure, the equipment should be isolated, or the boiler should be shut down before proceeding with the installation. Open drain valve to eliminate any trapped pressure. All inspection and installation steps should be performed by a qualified technician and should be executed in accordance with all applicable national and local codes.

Reliance®
A PRODUCT OF CLARK-RELIANCE

Repair Procedure

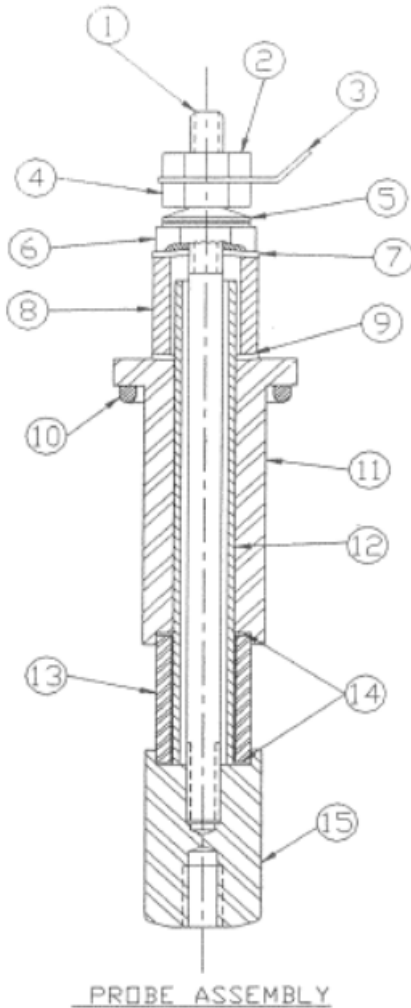

- 1) Clamp connector (Item 15) firmly in a vise and remove the terminal nut (Item 2), wire terminal (Item 3), and compression nut (Item 4).
- 2) Slide off remaining components from center rod (Item 1) and connector (Item 15).
- 3) Remove gasket debris from body (Item 11), connector (Item 15), and wetted insulator (Item 13).
- 4) Discard the following used components:
 - a. Belleville washers (Item 5)
 - b. Cushion washers (Items 7 & 9)
 - c. Standoff insulator (Item 8)
 - d. Sleeve insulator (Item 12)
 - e. Gaskets (Item 14)
- 5) Lubricate both sides of the Belleville washers and threads on the center rod with a high temperature Nickel based lubricant.
- 6) Reassemble as shown
 - a. Make sure to install the Belleville washers (Item 5) aligned with concave side facing the compression washer (Item 6).
 - b. Concave side of the compression washer (Item 6) must contact the cushion washer (Item 7) above the standoff insulator (Item 8) as shown.

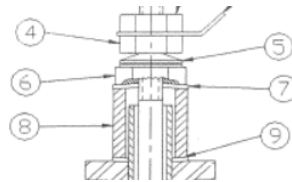

- 7) Grasp the connector (Item 15) and the probe body (Item 11) simultaneously to prevent the rotation of the components and destruction of the gaskets (Item 14) when tightening the compression nut (Item 4).
- 8) Torque the compression nut (Item 4) to 6 ft-lbs.
- 9) Inspect the probe for proper alignment of the components. Assembly is complete. Reinstall the probe per IOM #R500.E189A.
- 10) Slowly and carefully open the steam and water valves checking for any leakage. If a leak is observed, immediately isolate and drain the equipment, remove the probe and inspect for any misalignment or offset of the gaskets (Item 13). Repeat the procedure if necessary, using a new RK-33 Repair Kit.

Reliance[®]
A PRODUCT OF CLARK-RELiance

Item	Description	Quantity
1	Center rod **	1
2	Terminal nut	1
3	Wire terminal	1
4	Compression nut	1
5	Belleville washer	3
6	Compression washer	1
7	Cushion washer	1
8	Standoff insulator	1
9	Cushion washer	1
10	Sealing gasket	1
11	Flanged Probe body **	1
12	Sleeve insulator	1
13	Wetted insulator **	1
14	Grafoil gaskets	2
15	Connector **	1

** Parts not furnished in the repair kit

Notes:

Any additional questions should be directed to your local Clark-Reliance Representative, or to the Factory. Phone: (440) 572-1500 or email www.relianceappeng@clark-reliance.com.





On-Line Parts – DIRECT – for Clark-Reliance Products

JERGUSON® **Reliance®**

JACOBY-TARBOX® **MAGNE-SONICS®**



www.clark-reliance.com/parts

Reliance®
A PRODUCT OF CLARK-RELIANCE